

Natural Refrigerant Training Summit

Building a Sustainable Workforce

Understanding Booster Oil Systems

Rusty Walker

NASRC



NORTH AMERICAN
Sustainable
Refrigeration
Council

Natural Refrigerant Training Summit

Thank you to our sponsors!

Premium Sponsors



COPELAND

Hillphoenix
A DOVER COMPANY

Basic Sponsors

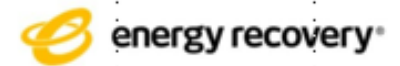

HUSSMANN



TRUE

Who We Are

A 501c3 nonprofit working to create a sustainable future for supermarket refrigeration by removing barriers to natural refrigerant adoption.

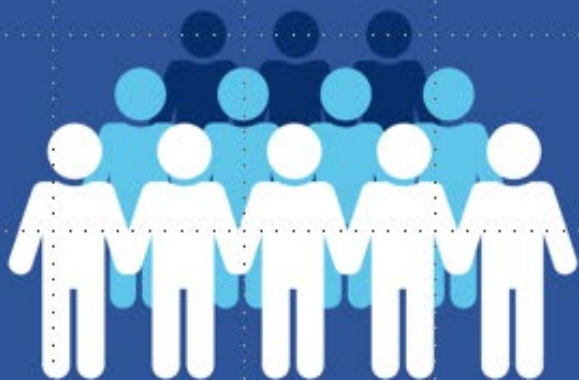

160+
member
companies



55K+
food retail
locations



Goals

-  Build a sustainable technician workforce
-  Increase funding for natural refrigerant equipment
-  Improve technology options, education, and awareness

What are Natural Refrigerants?

CO_2

R744
Carbon Dioxide

C_3H_8

R290
Propane

NH_3

R717
Ammonia



NORTH AMERICAN

Sustainable Refrigeration Council

Day 3 Hands-On Breakout Sessions

Thursday, March 21

Start	End	Training Provider	Session Title
6:30 AM	7:30 AM		REGISTRATION & BREAKFAST
7:30 AM	7:50 AM	Various	20-minute hands-on breakout sessions* <i>(sign-up required)</i>
8:00 AM	8:20 AM	Various	20-minute hands-on breakout sessions* <i>(sign-up required)</i>
8:30 AM	8:50 AM	Various	20-minute hands-on breakout sessions* <i>(sign-up required)</i>
9:00 AM	9:30 AM		BREAK
9:30 AM	9:50 AM	Various	20-minute hands-on breakout sessions* <i>(sign-up required)</i>
10:00 AM	10:20 AM	Various	20-minute hands-on breakout sessions* <i>(sign-up required)</i>
10:30 AM	10:50 AM	Various	20-minute hands-on breakout sessions* <i>(sign-up required)</i>
11:00 AM	12:00 PM		LUNCH & EXHIBIT HALL
12:00 PM	12:20 PM	Various	20-minute hands-on breakout sessions* <i>(sign-up required)</i>
12:30 PM	12:50 PM	Various	20-minute hands-on breakout sessions* <i>(sign-up required)</i>
1:00 PM	1:20 PM	Various	20-minute hands-on breakout sessions* <i>(sign-up required)</i>

- 20-minute, small group sessions
- Space is limited
- **Must sign-up at Info Desk**
- Scan the QR code for session information



Need help? Look for NASRC staff!



Danielle Wright
Executive Director



Morgan Smith
Program & Communications Director

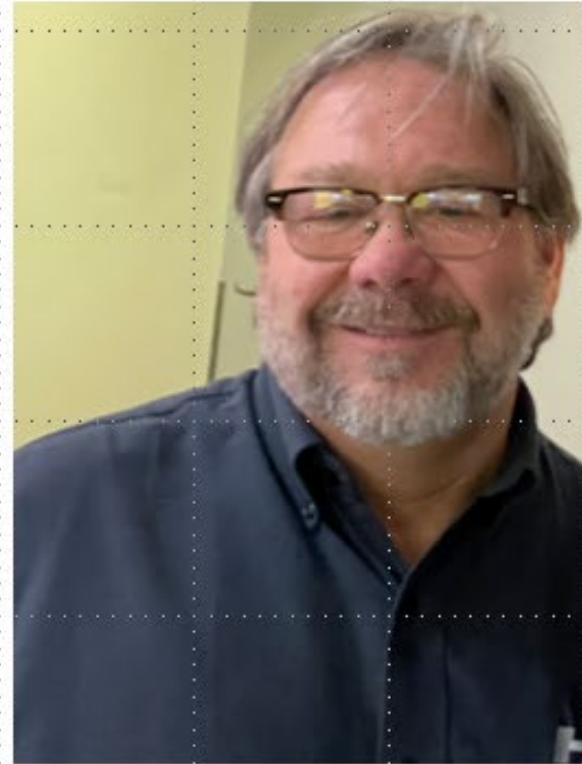

Rusty Walker
Training Director



NORTH AMERICAN
**Sustainable
Refrigeration
Council**

Troubleshooting A Booster Oil System

Rusty Walker

Booster Flex Low and Medium Temp Compressors



Bitzer Medium Temperature Booster Compressor

No Oil Pump



Copeland Medium Temperature Booster Compressor

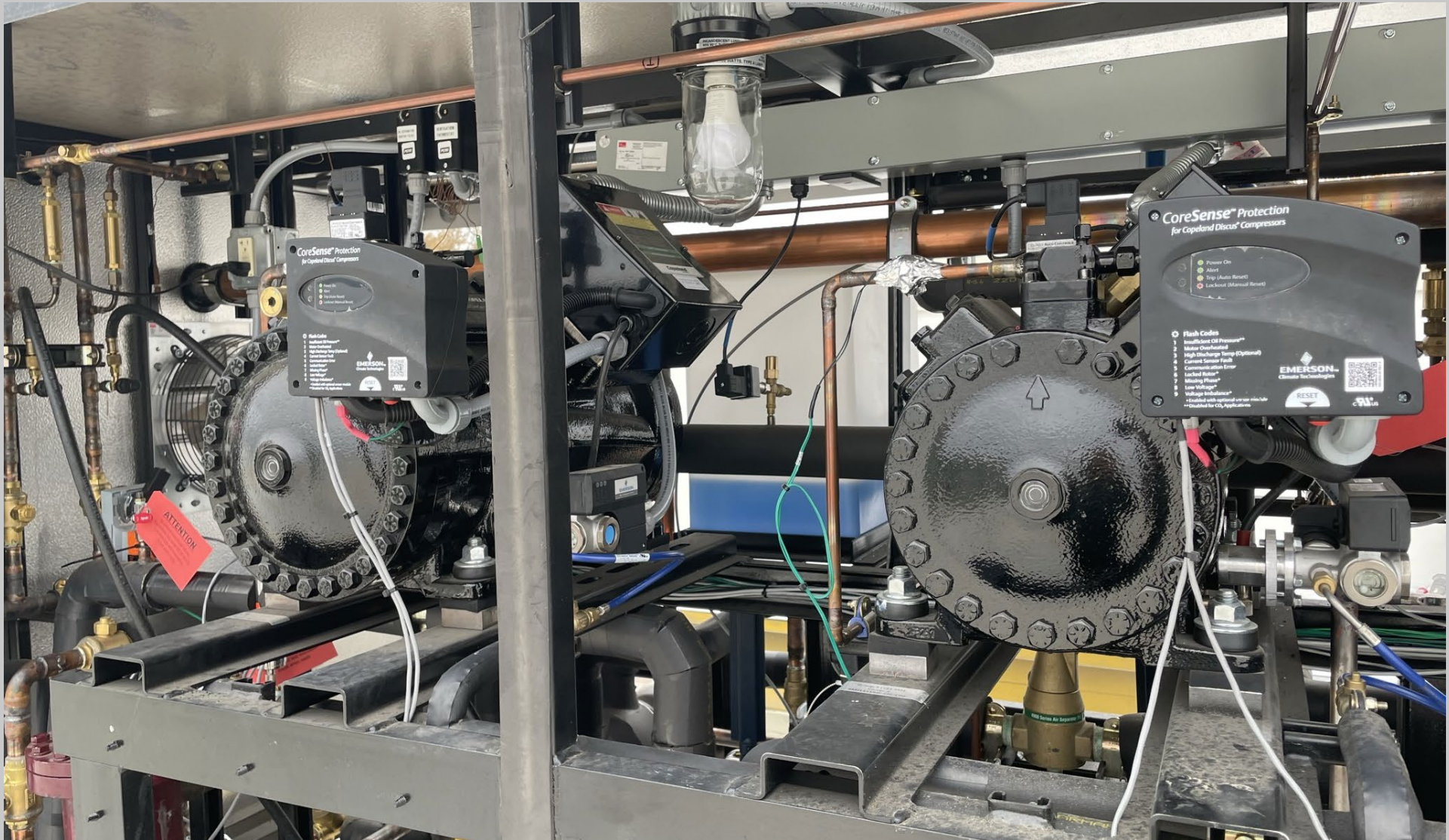

Medium Temperature Compressor Oil Sling



Low Temperature Reciprocating Compressor



Centrifugal Oil Cup



Centrifugal Oil System



Bitzer Crank Shaft

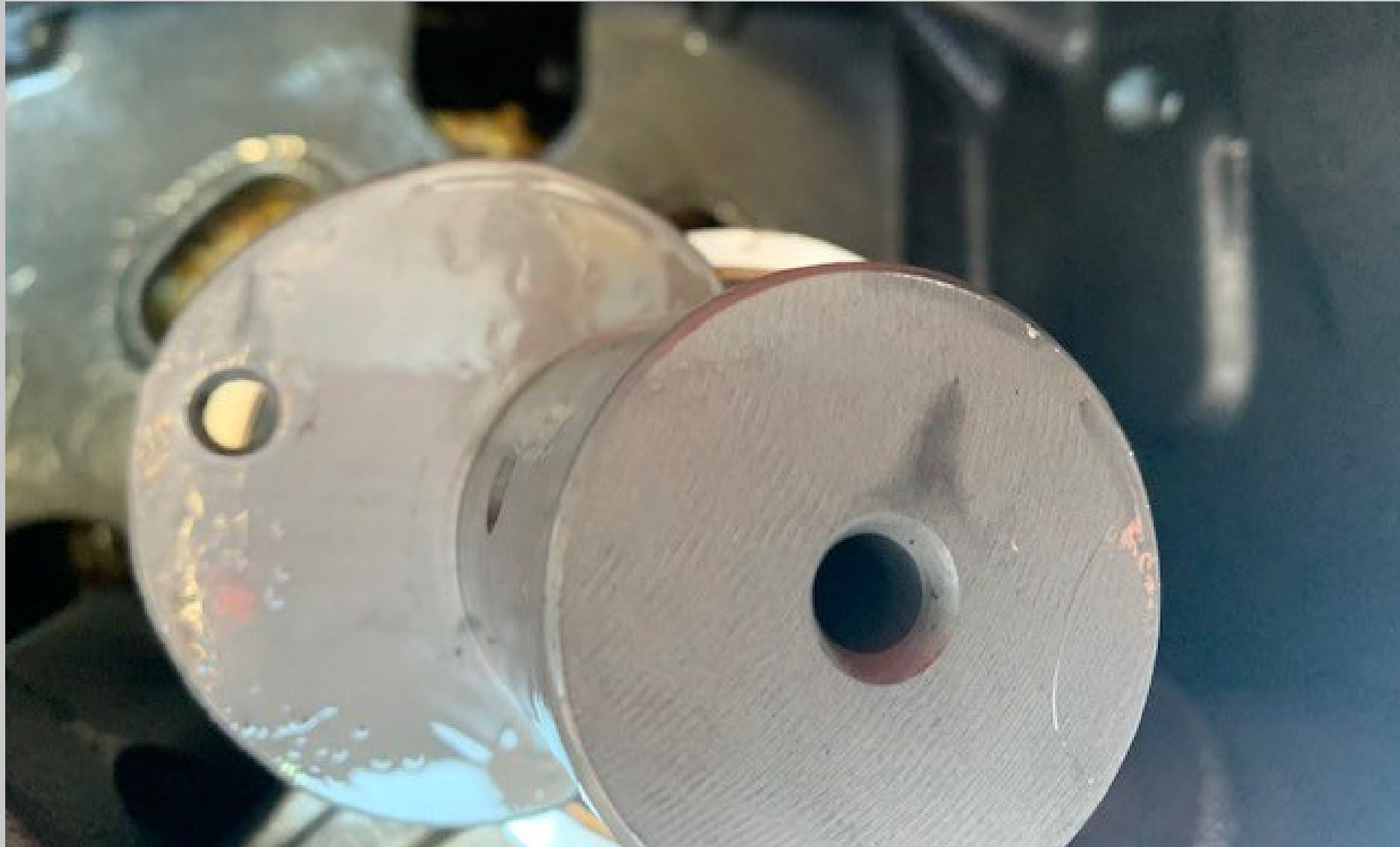



NORTH AMERICAN
**Sustainable
Refrigeration
Council**

Discharge Separator and Oil Reservoir

Booster Oil System with OMC/Kriwan

The oil solenoid valve opens when the oil level reaches a HBS01 oil sensor. Allowing oil to transfer from the separator to the oil reservoir

Oil line to the high pressure oil floats (OMC or Kriwan) located on the side of each compressor

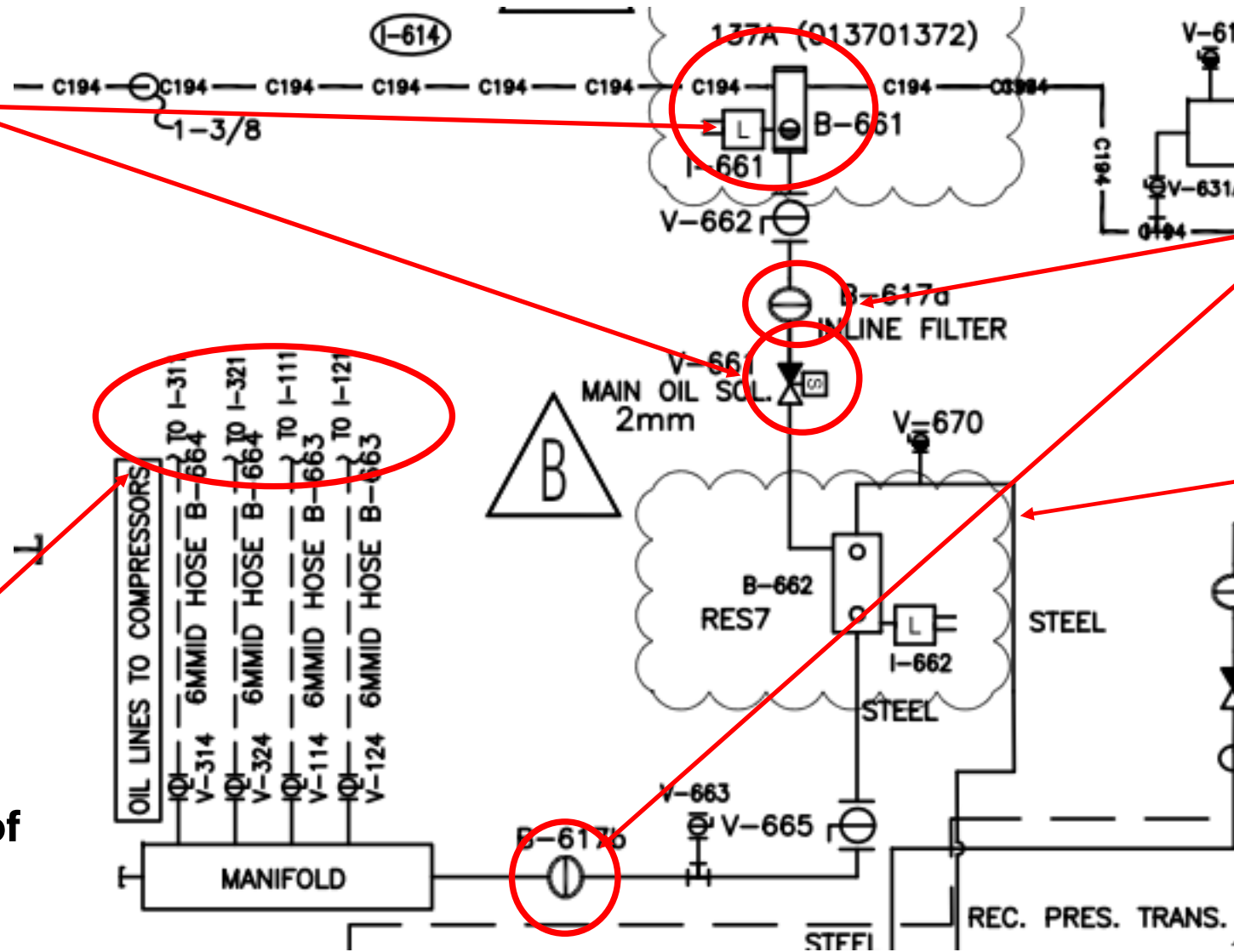

Inline oil filters must be cleaned during yearly PM or any time they are plugged or that you are changing the oil separator filter

Reservoir Vent Line vents discharge gas from the separator to flash tank, whenever the solenoid energizes this keeps the oil reservoir at 515 psig

Coalescent Discharge Oil Separators

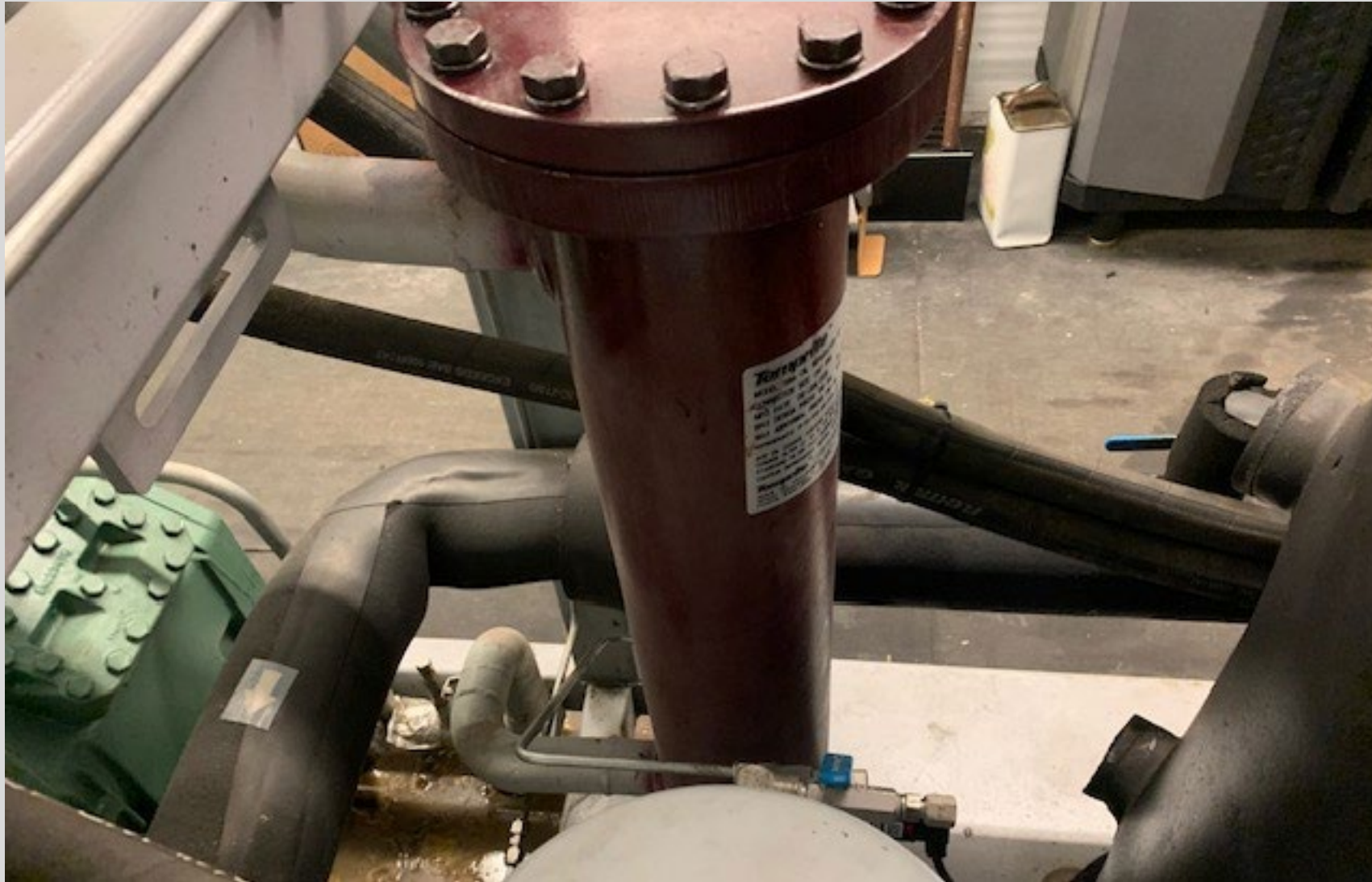

Coalescent Discharge Oil Separator



Temp Rite Oil Reservoir with HB Oil Sensor

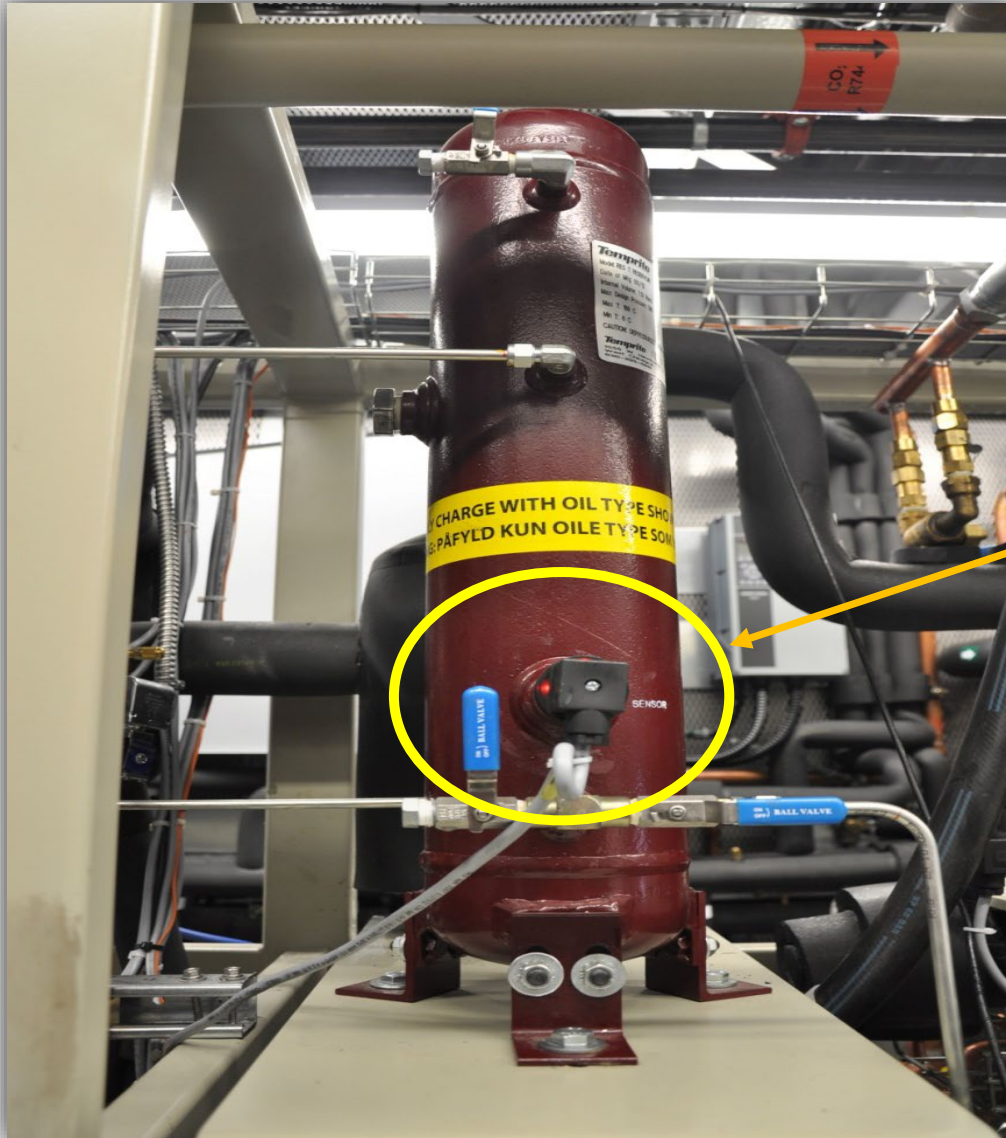

Red light on the HBSO1 oil switch indicate there is oil in the reservoir



Westermeyer Oil Reservoir



Green light on the HBSO1 oil switch indicate there is no oil in the reservoir

Oil Reservoir with Solenoid



HB Sensor on Westermeyer Oil Reservoir

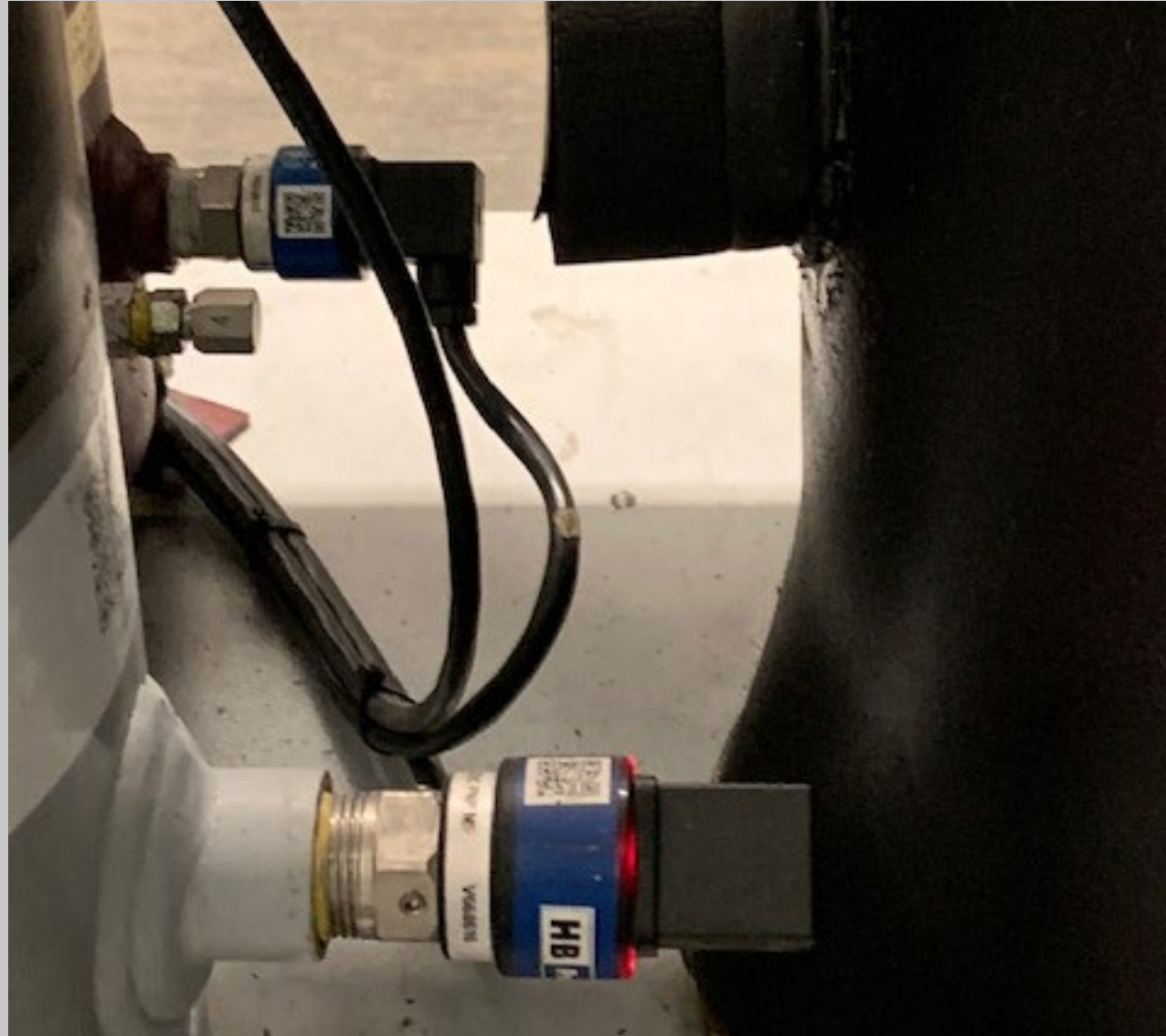

HBSO1 Oil Sensor

Functionality

The switches are used for detecting liquid in gas or air (HBOR detect oil in liquid ammonia). The mechanical elements have different design because they are optimized to different liquids. The switches use the **capacitive measuring principle** and react to the difference in dielectric constant between liquid and gas.

Switching

All switches except HBOR switch on when liquid is detected. This means a NO switch close the contact when liquid is detected, and a NC open the contact when in liquid

HBOR is different: it switches off when oil is detected

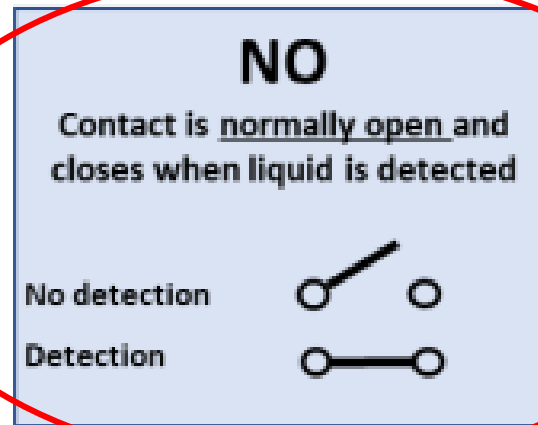

LED indication

4 x red LED's indicate liquid/oil detection.

4 x green LED's flashing indicate no detection, but sensor is active.

4 x red flashing LED's indicate no connection to mechanical unit.

Irrespective of the output function (NO/NC) LED's are activated when liquid is detected.



NORTH AMERICAN

Sustainable Refrigeration Council

HBSC2 Refrigerant Sensor & HBSO1 Oil Sensor



24V AC/DC power to the switch

HBSC2 Refrigerant Sensor/Switch, normally open

HBSO1 POE oil Sensor/Switch, normally open

HBSO1 Oil Sensor & HBSC2 Refrigerant Sensor Pickups



HBSO1 Oil Sensor pickup

HBSC2 Refrigerant Sensor pickup

Troubleshooting the HBSO1 Oil Sensor

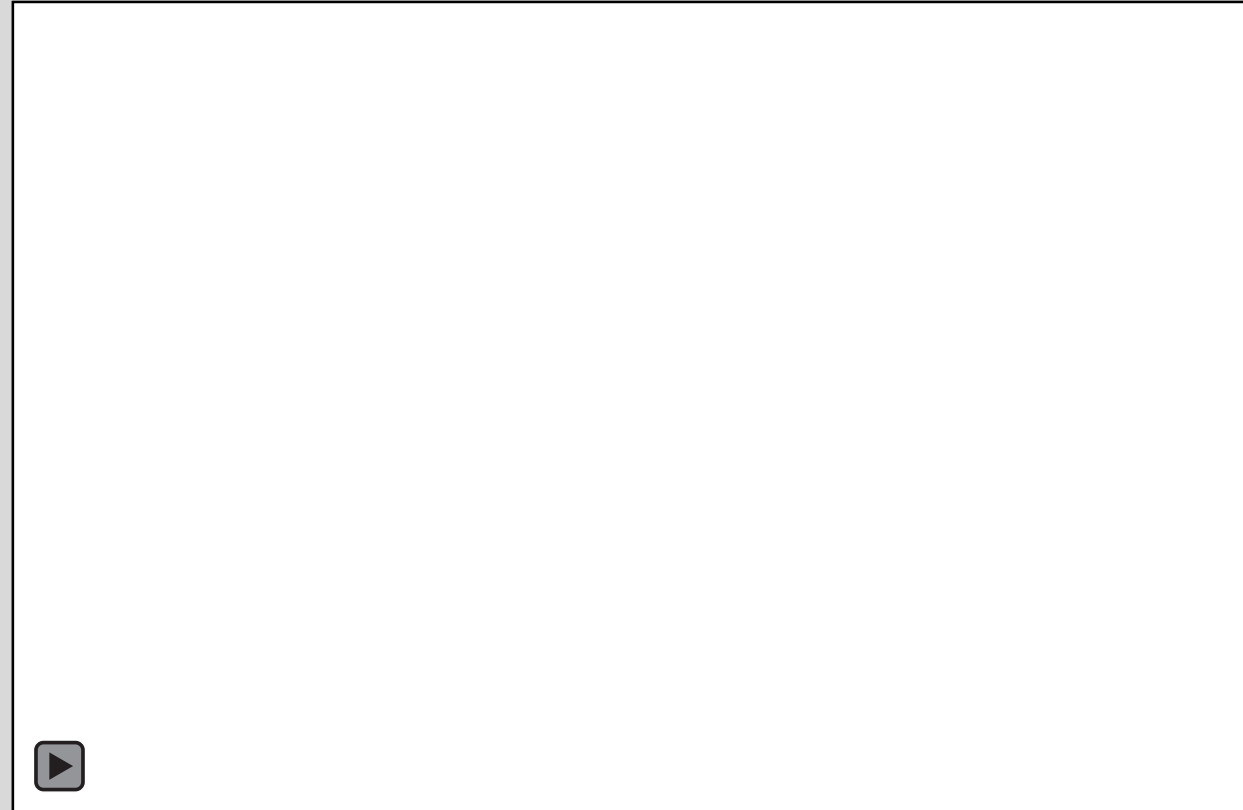

Oil System Diagram

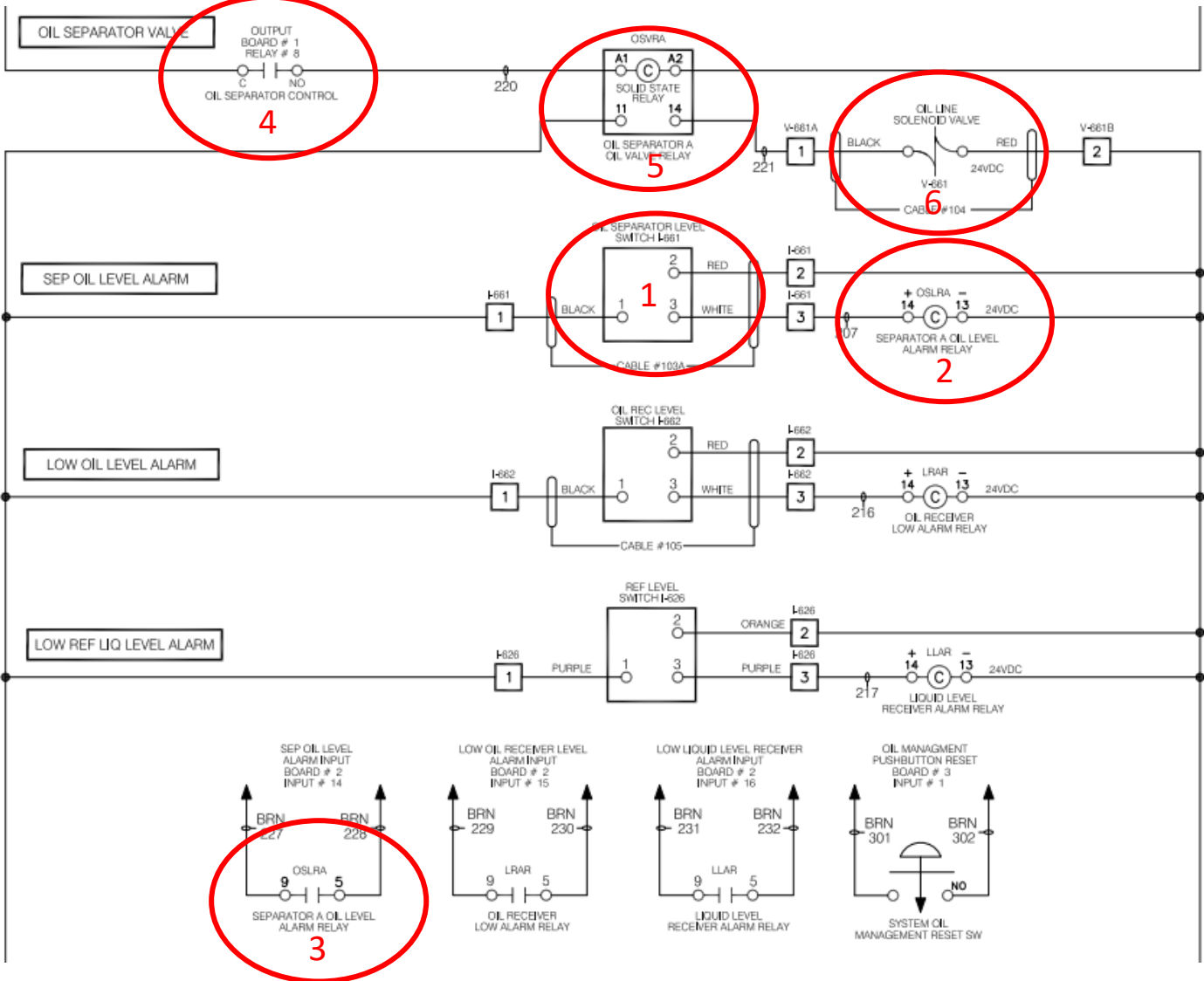

Discharge Oil Separator Relay

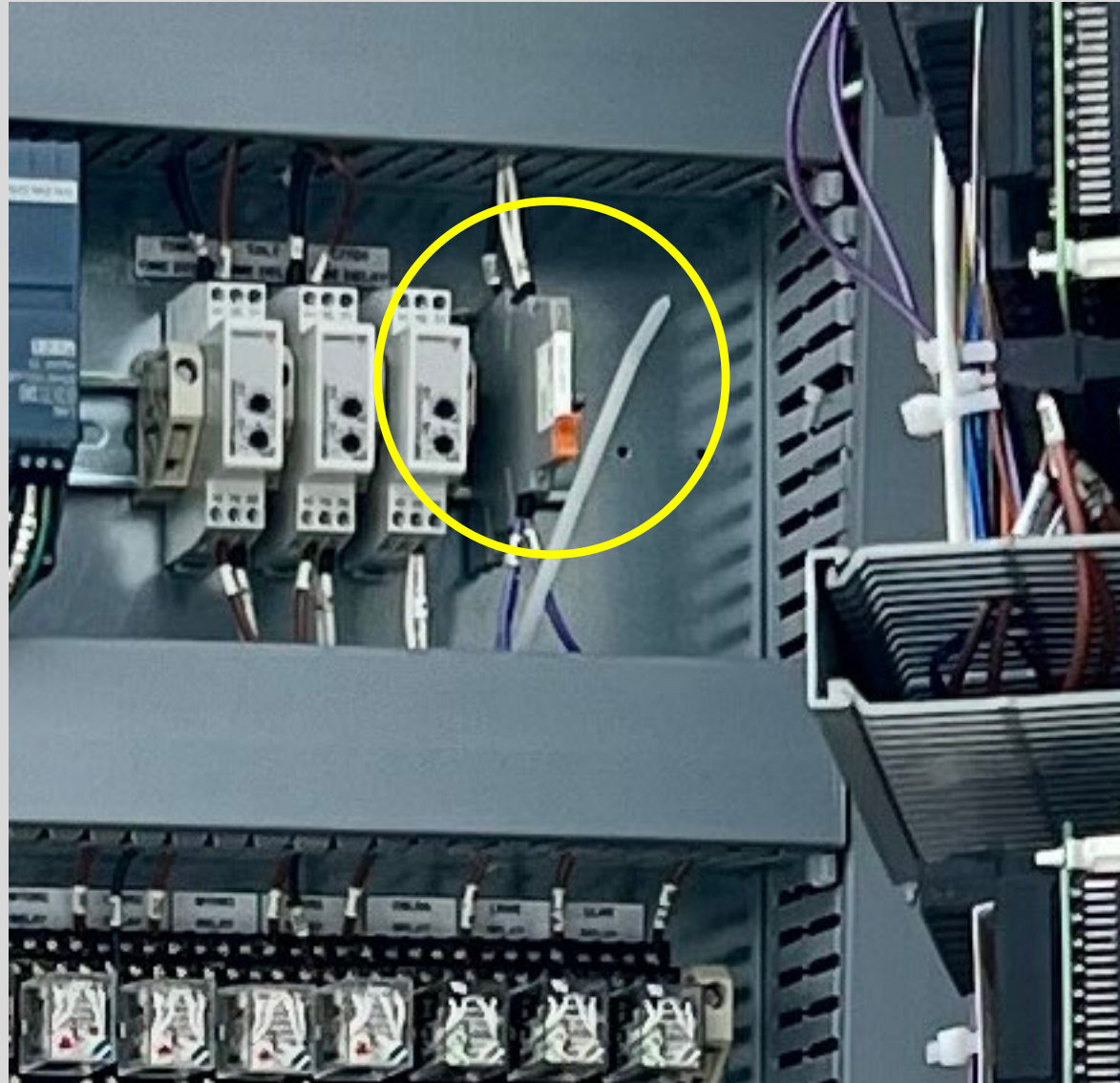

Oil line Filter on Discharge Oil Separator



In-Line Oil Filter

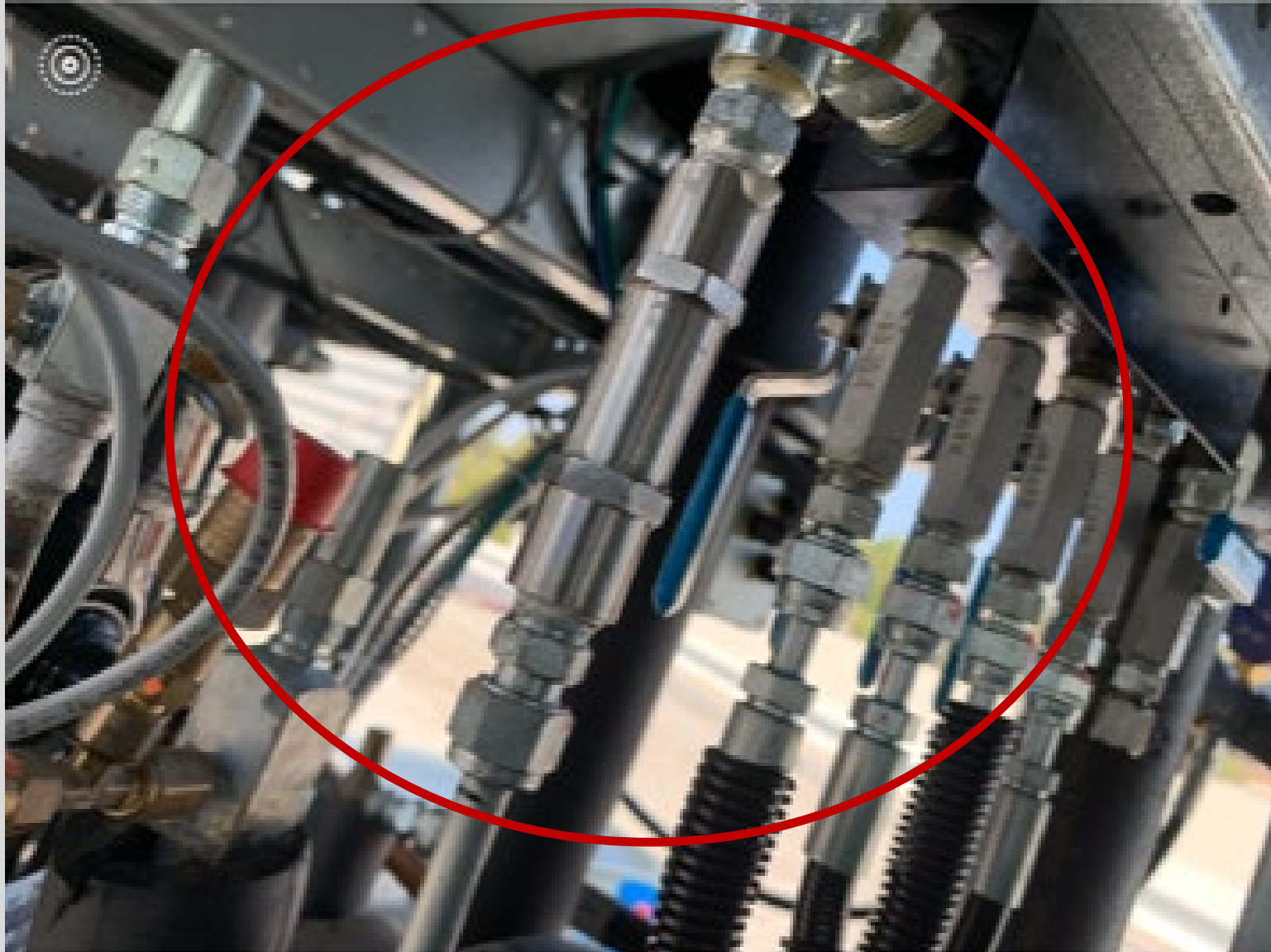

Oil Filter Element

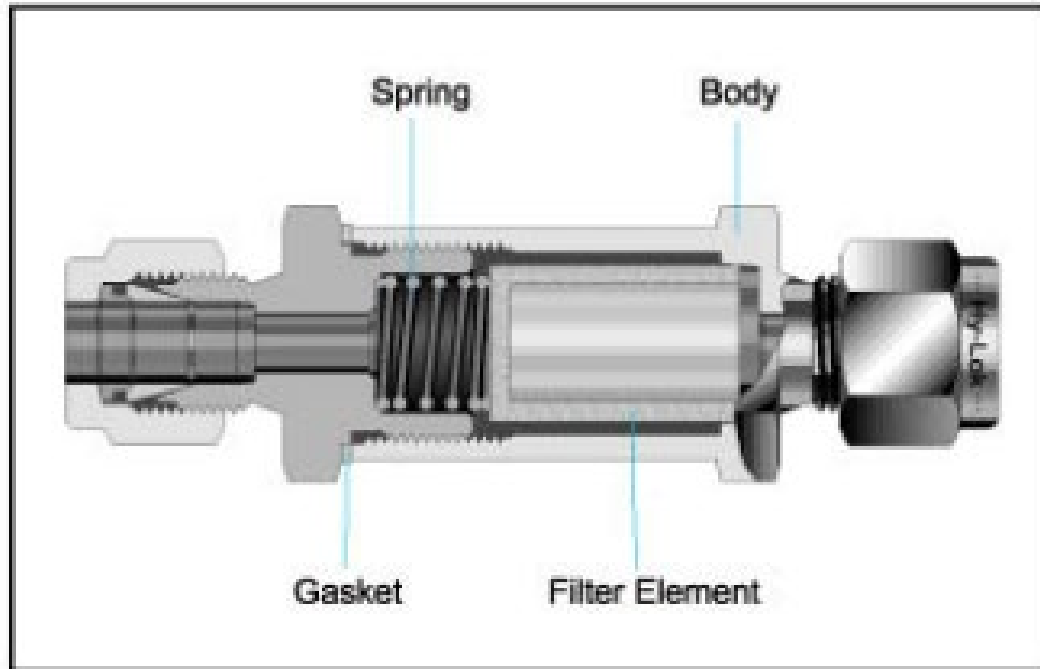

Features

- In-line filters are for use where space is limited
- Replaceable Filter element
- Particle trapping for clean fluid



Plugged Oil Filter Element



Low Oil Reservoir Alarm



Misdiagnosed Low Temperature Compressor

Oil System Solenoids used with HB Sensor

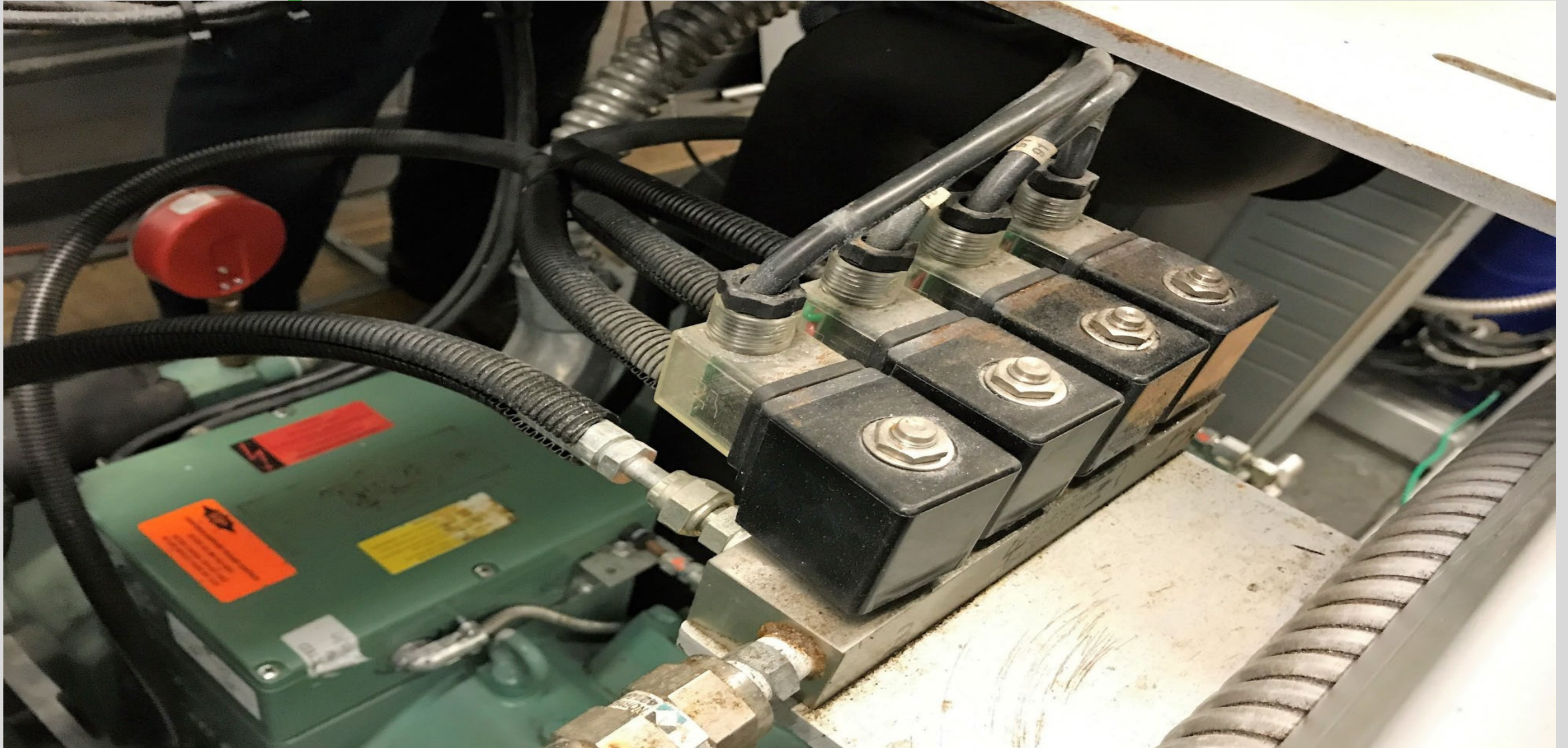

HB Capacitive Oil Level Sensor

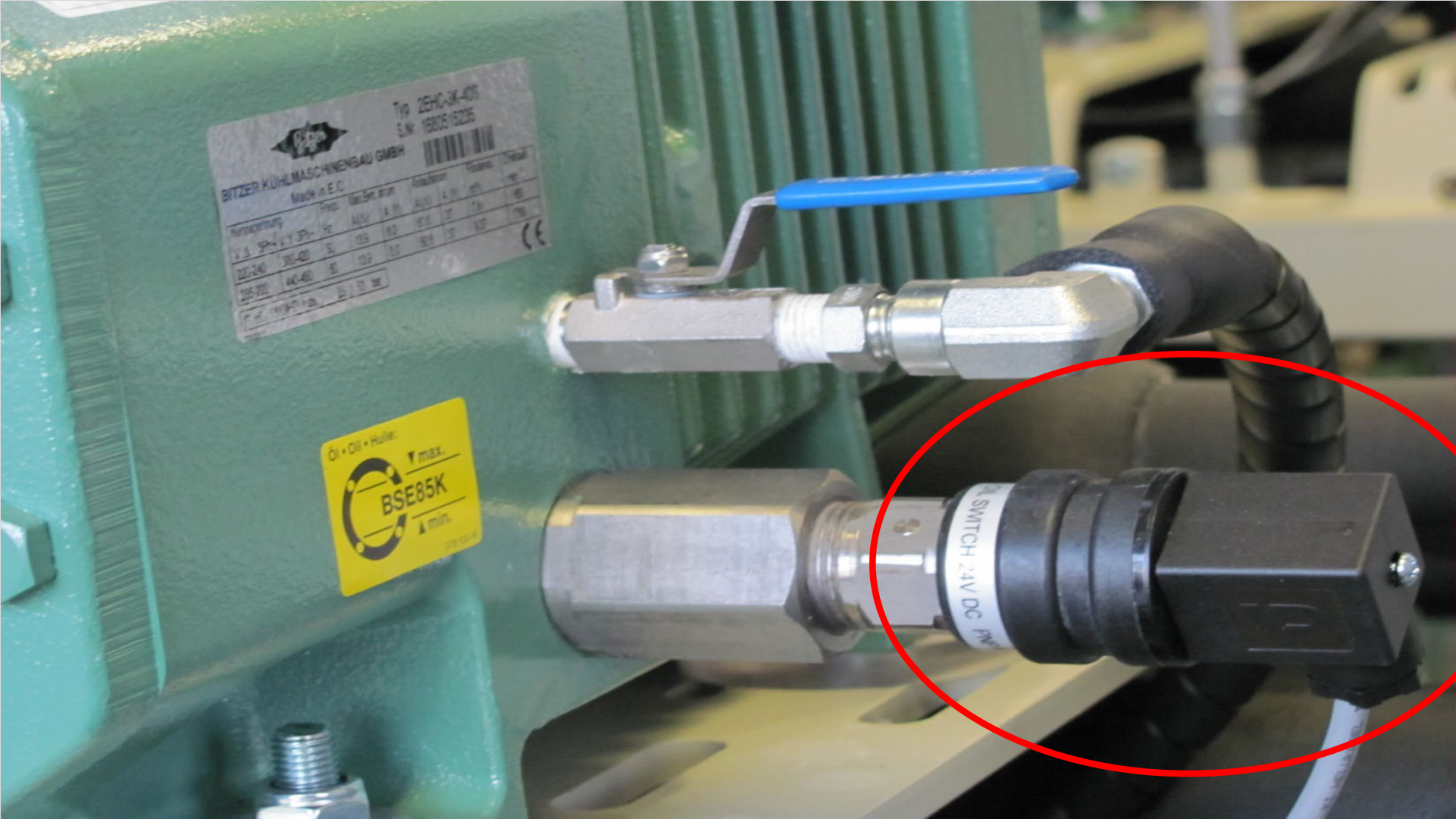

HB Sensor Oil System Electrical

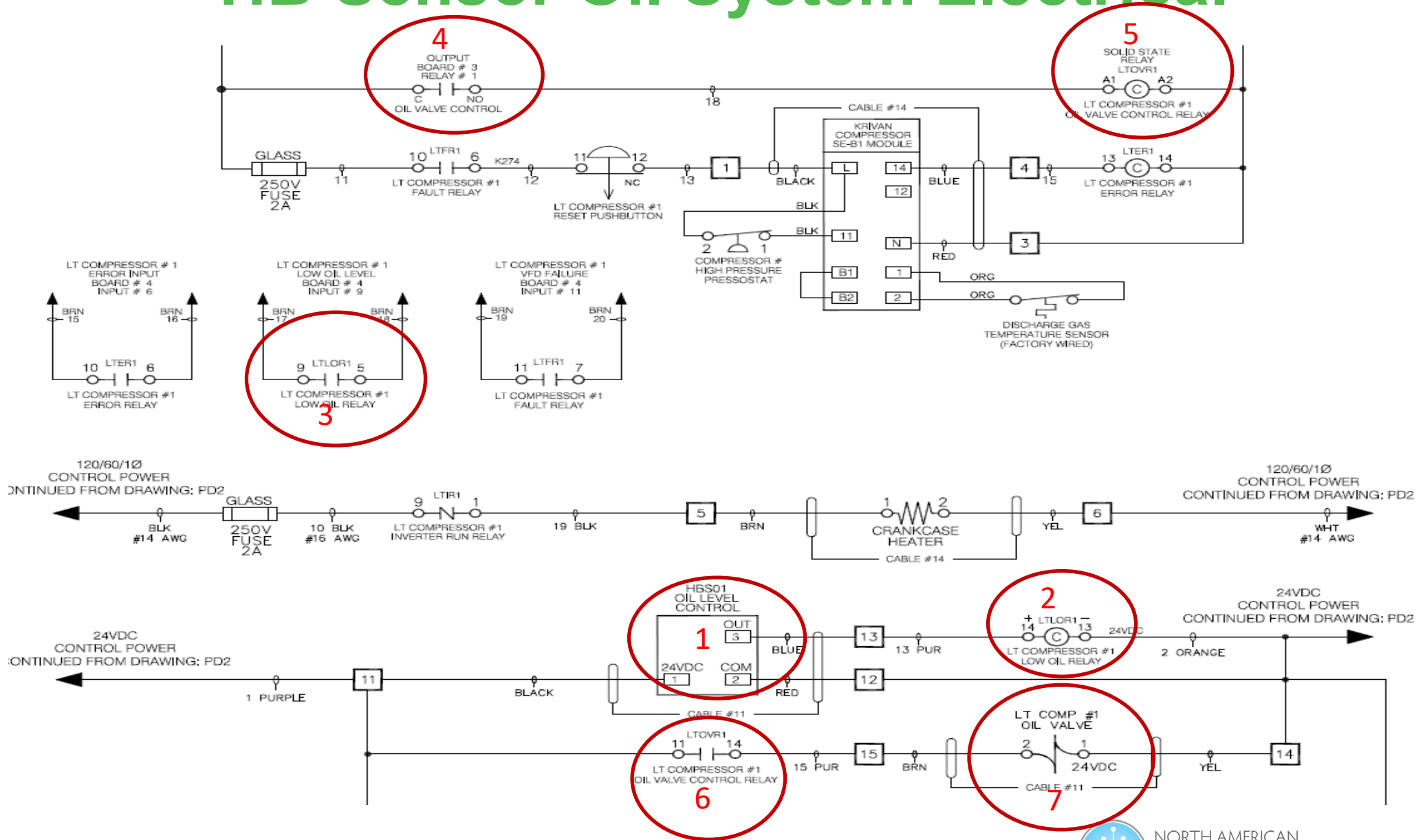



NORTH AMERICAN
**Sustainable
Refrigeration
Council**

High Pressure Oil Systems OMC/Kriwan

Low Temperature Compressor's OMC



Low Temperature OMC D120



High Pressure Oil Sensor OMC

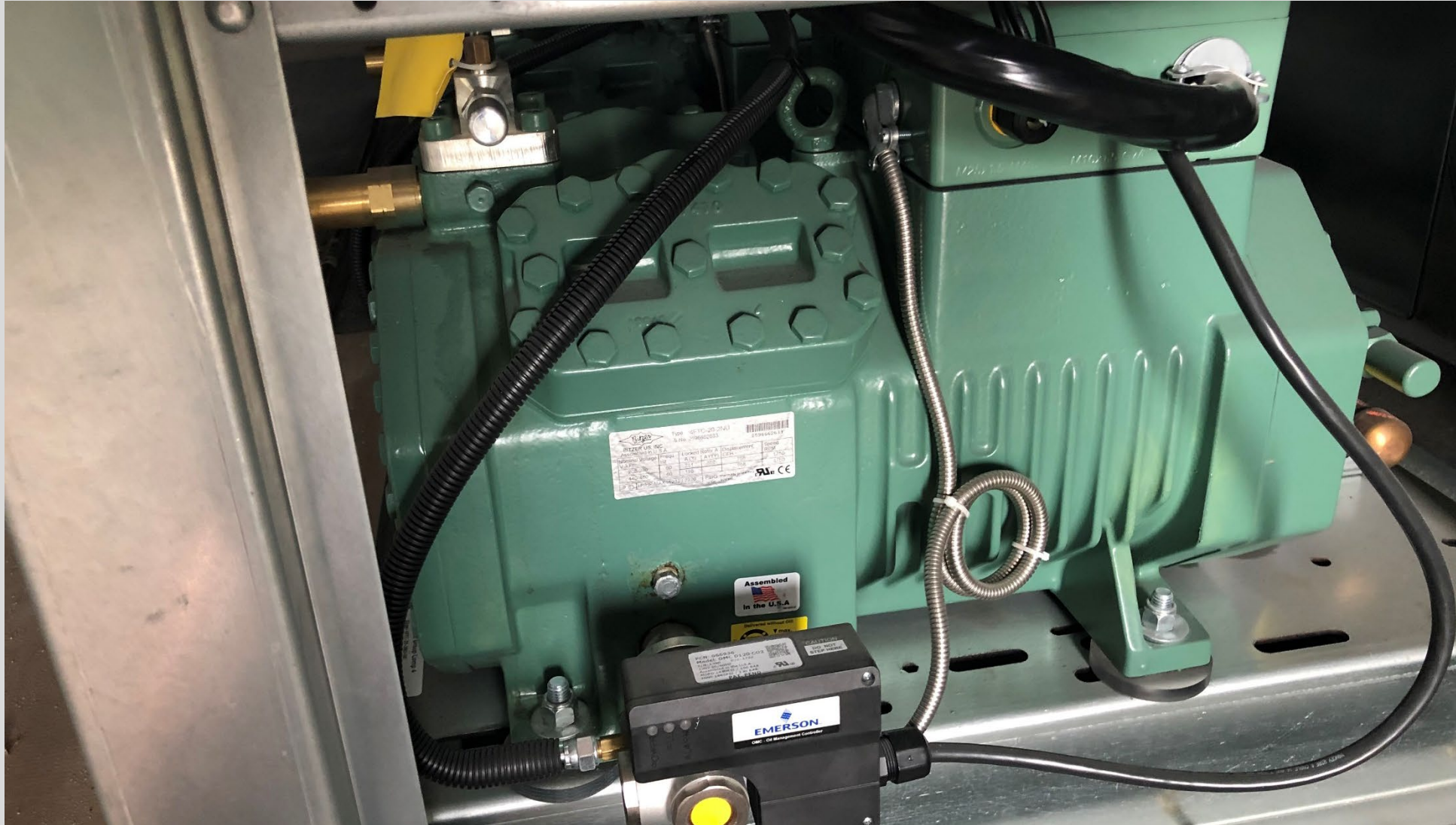

High Pressure Oil Sensor OMC



Medium Temperature Compressor OMC D120 CO2



Kriwan High Pressure Oil Float INT280-130



Kriwan High Pressure Oil Float

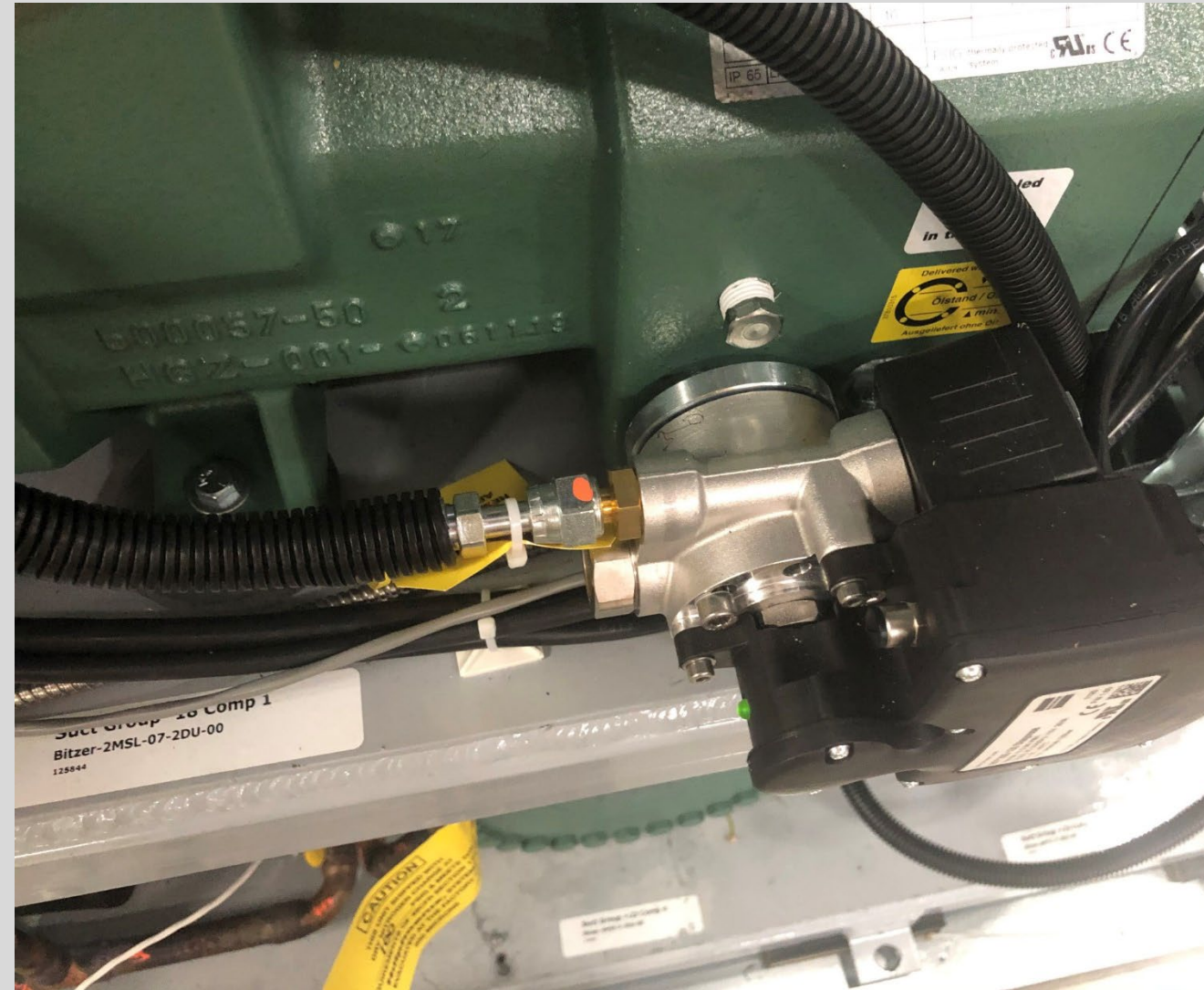
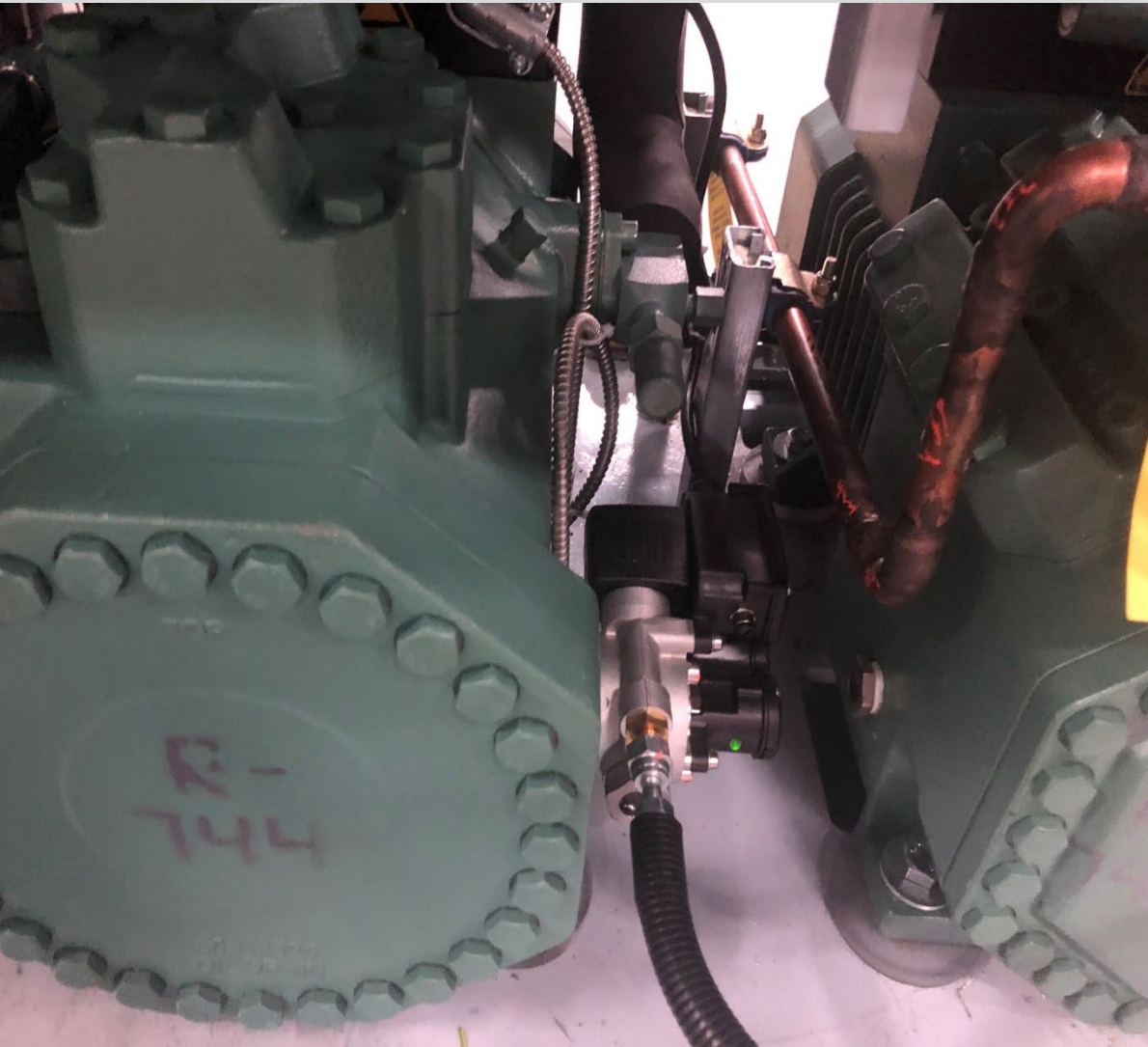

Oil Relays

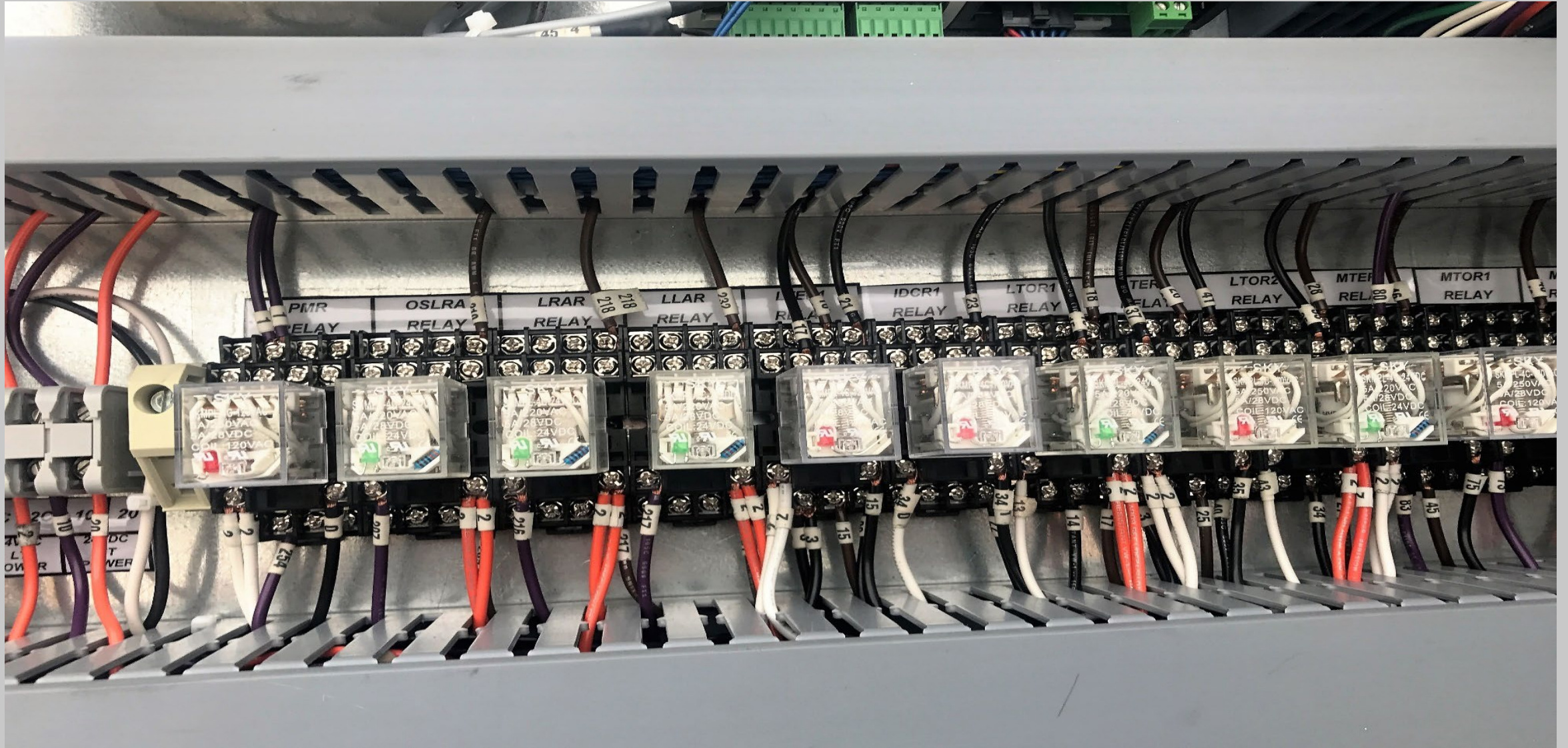

Why Are We Having Oil Alarms





NORTH AMERICAN
**Sustainable
Refrigeration
Council**

What Oil Should I Use??

CO2 Proper Piping Procedure

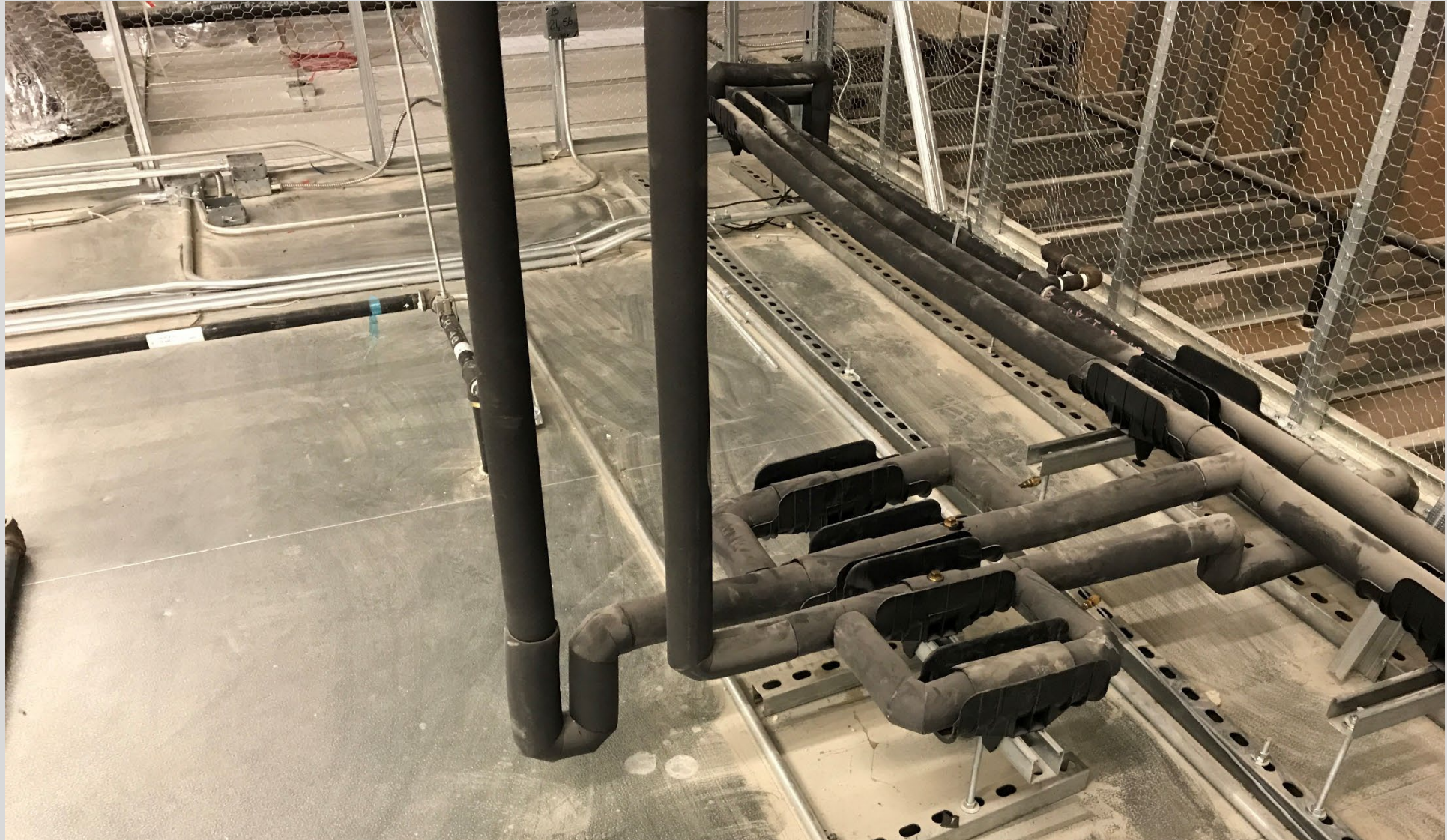

Suction Line Oil Trap



BSE85K Bitzer Booster Oil



Quick Ship Program Locations



QUICKSHIP PROGRAM LOCATIONS

1 888 Go Bitzer (462.4893)



NORTH AMERICAN
Sustainable Refrigeration Council

Wrong Oil



Save the Valve Plates





NORTH AMERICAN
**Sustainable
Refrigeration
Council**

Changing out a Coalescence Cartridge

Discharge Oil Separators

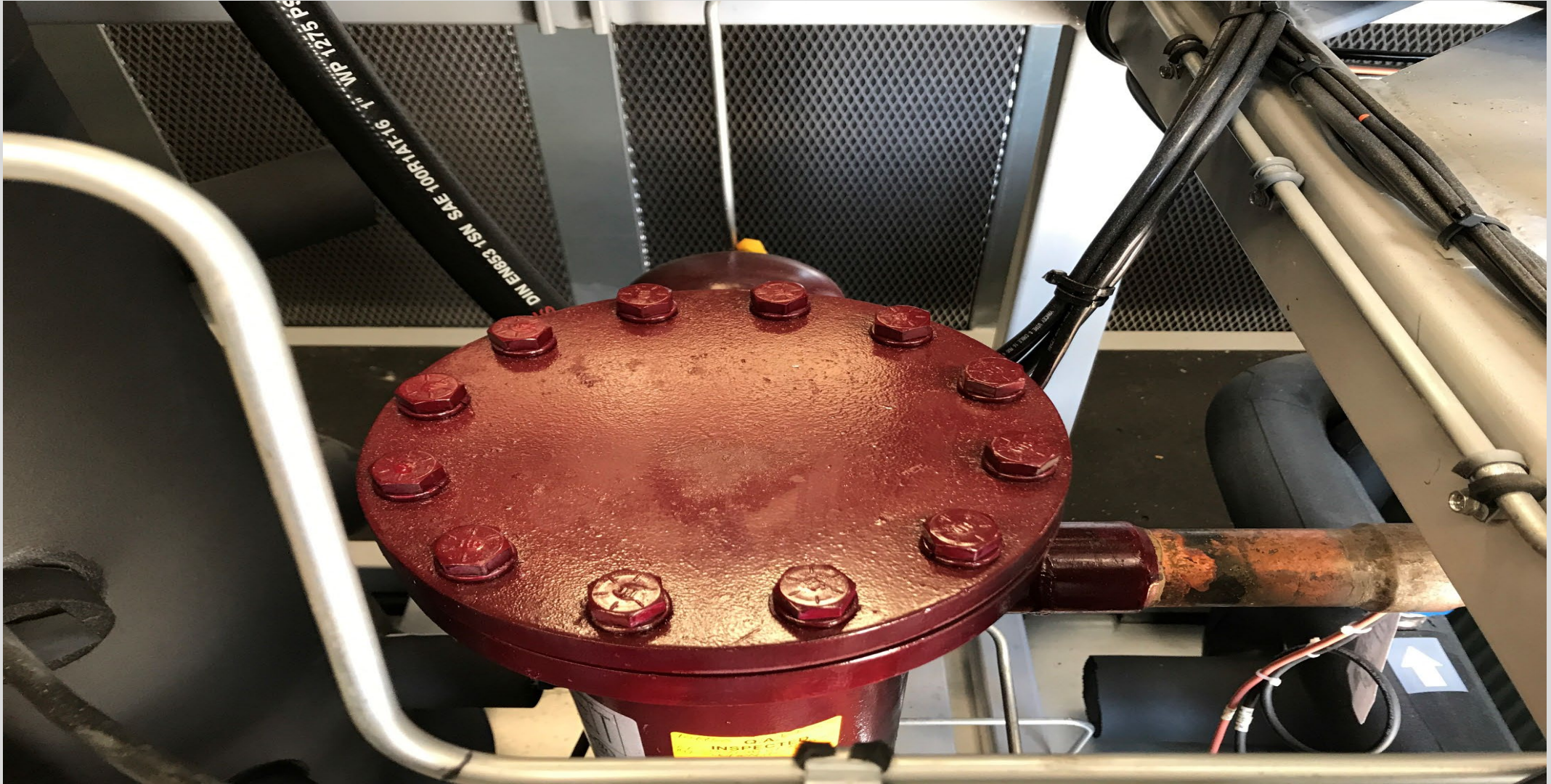

Spider with Cartridge



Westermeyer Oil Reservoir and Coalescing Oil Separator



Westermeyer Coalescing Oil Separator

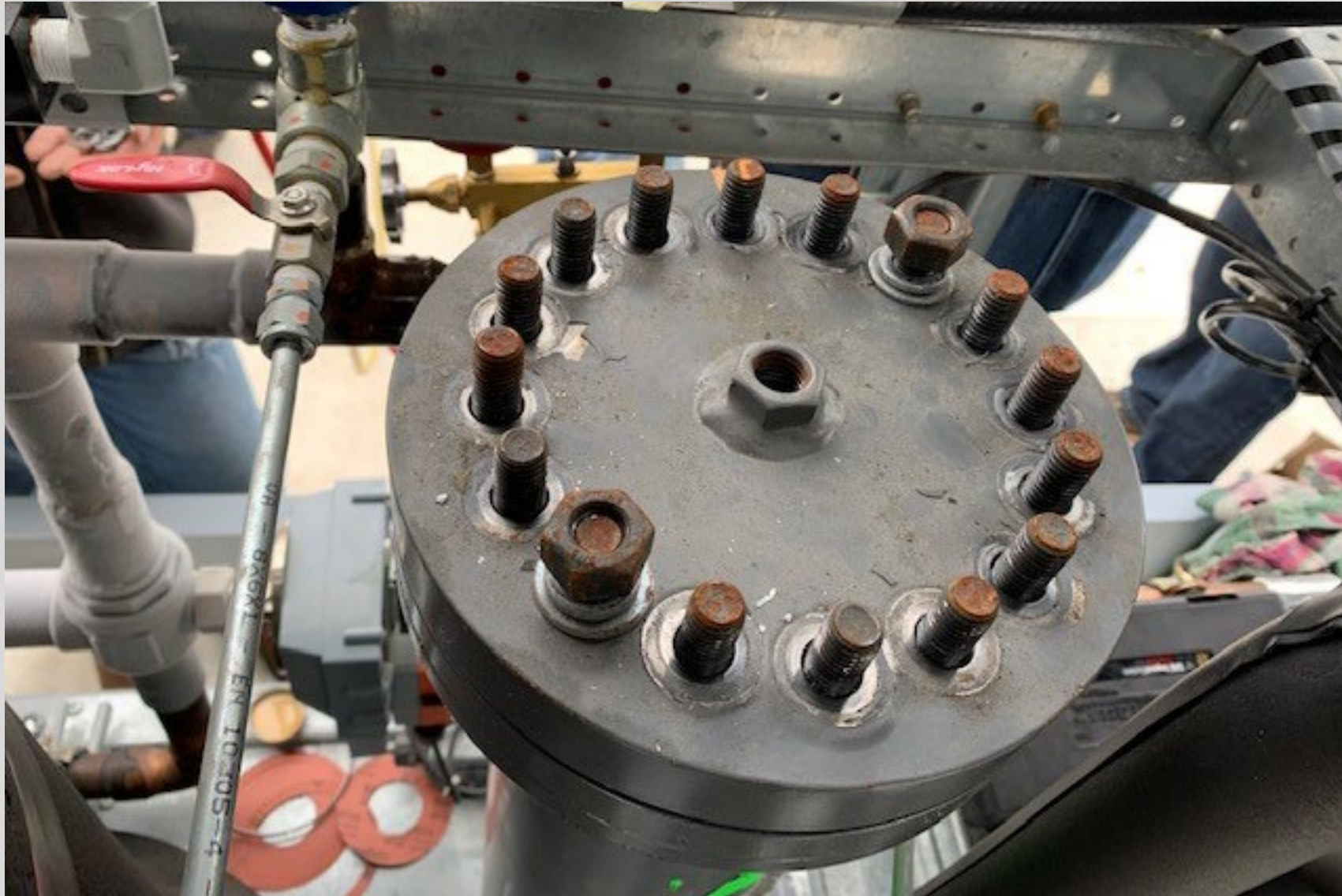

Westermeyer Coalescing Oil Separator



Westermeyer Coalescing Oil Separator



Gone Fishing

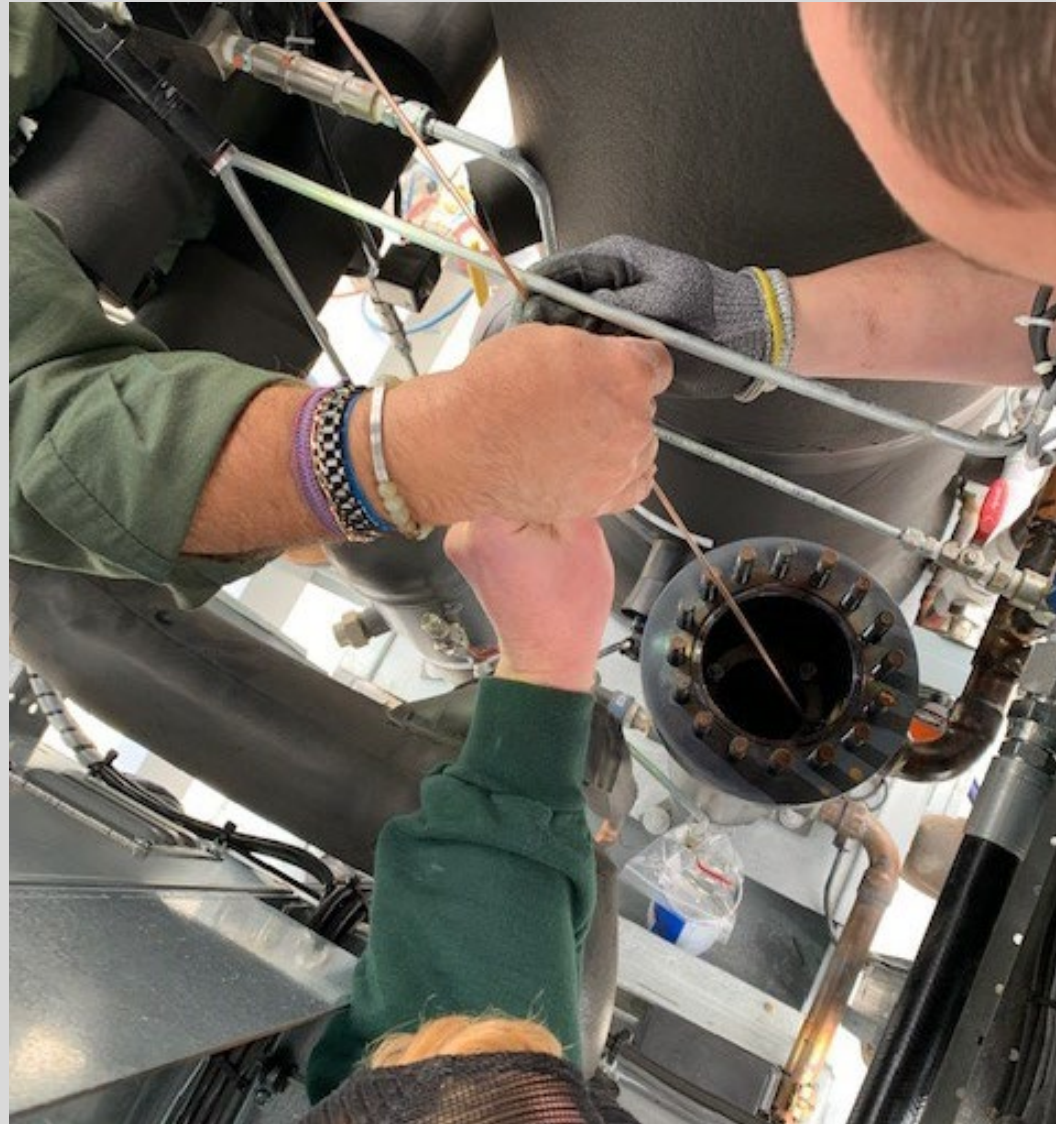

Gasket on the Temprite Cartridge

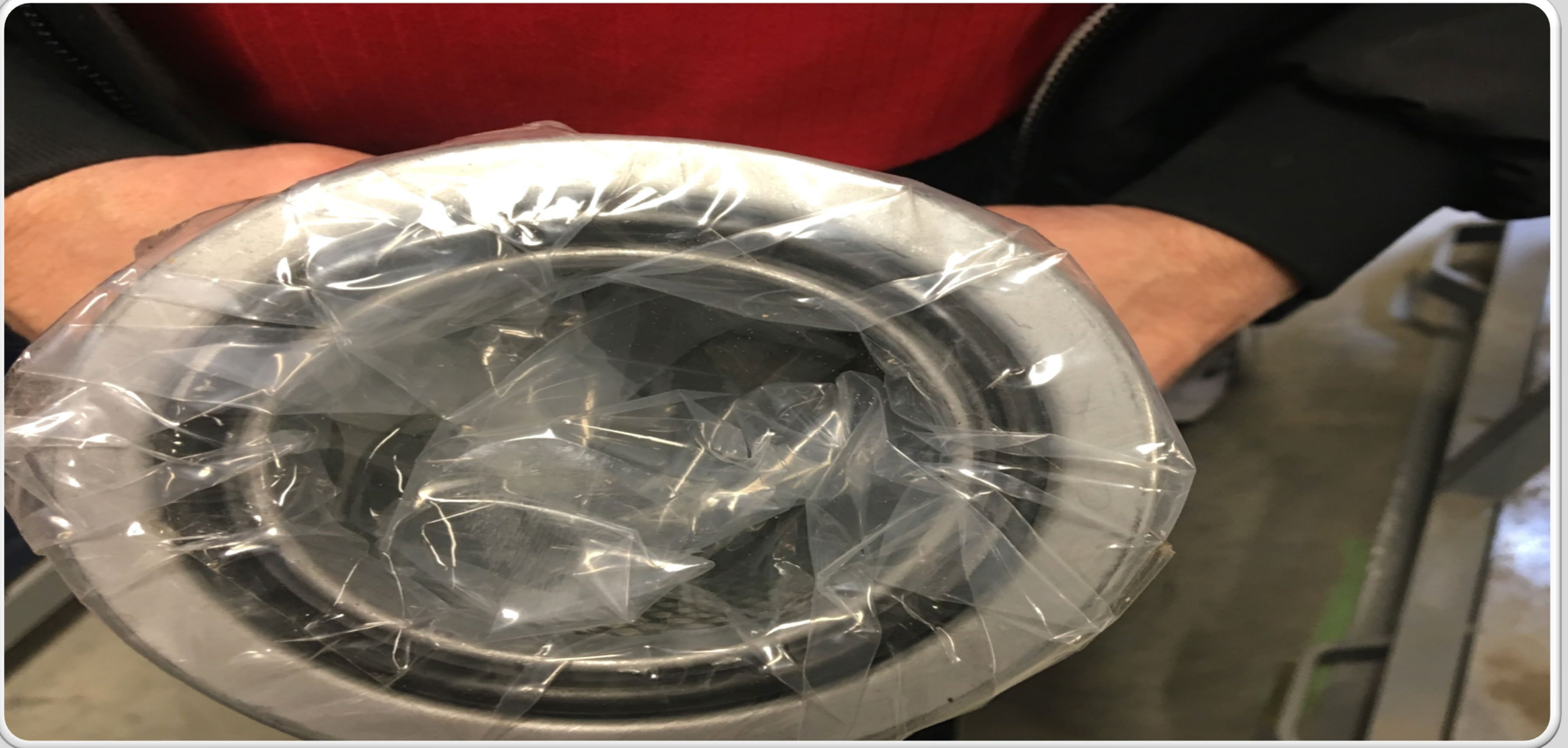

Westermeyer Coalescing Oil Filters



Oil Separator Cartridge with Lid Gasket



Westermeyer Coalescing Steel Gasket



Discharge Oil Separators

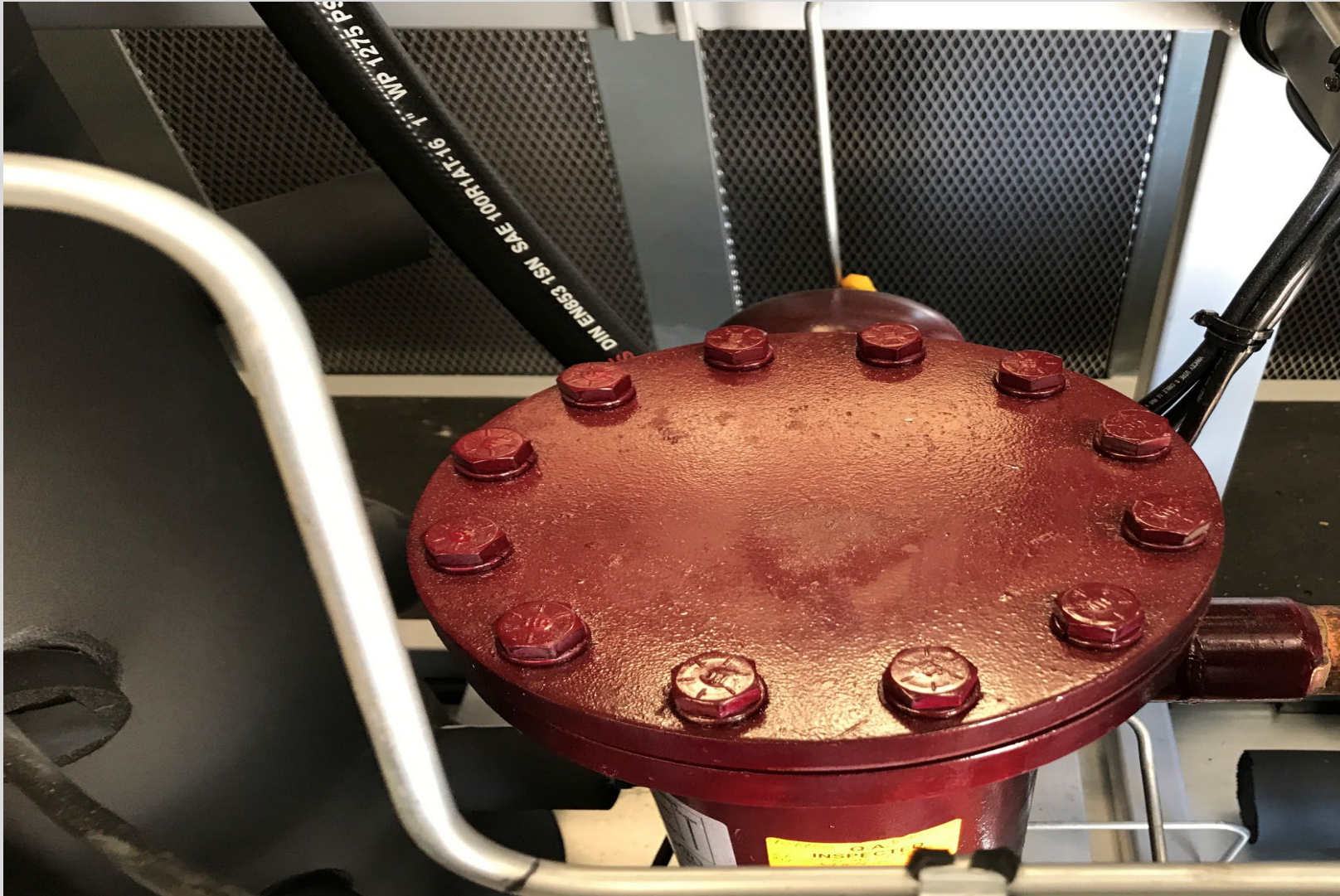

- Remember to tighten lid in a star pattern to 50 ft/lb

Westermeyer Coalescing Oil Separator



Remember to tighten lid in a star pattern to 55 ft/lb



Westermeyer Coalescing Oil Separator



Westermeyer Coalescing Oil Filter



Westermeyer Coalescing Oil Filter



Questions



Share Your Feedback!



To receive an electronic training certificate:

1. Scan or visit nasrc.org/session-surveys
2. Provide your name and email at the end of the survey

Please Note: You will not receive a certificate unless you share your name on the survey form.

Understanding Booster Oil Systems

Rusty Walker

NASRC