

# Natural Refrigerant Training Summit

Building a Sustainable Workforce

---

## Debunking CO2 Myths

Rusty Walker

NASRC



NORTH AMERICAN  
Sustainable  
Refrigeration  
Council

# Natural Refrigerant Training Summit

## Thank you to our sponsors!

### Premium Sponsors



**COPELAND**

**Hillphoenix**  
A DOVER COMPANY

### Basic Sponsors

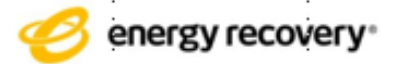

**HUSSMANN**



**TRUE**

# Who We Are

A 501c3 nonprofit working to create a sustainable future for supermarket refrigeration by removing barriers to natural refrigerant adoption.



**160+**  
member  
companies



**55K+**  
food retail  
locations



# Goals

-  Build a sustainable technician workforce
-  Increase funding for natural refrigerant equipment
-  Improve technology options, education, and awareness

## What are Natural Refrigerants?

**CO<sub>2</sub>**

**R744**  
Carbon Dioxide

**C<sub>3</sub>H<sub>8</sub>**

**R290**  
Propane

**NH<sub>3</sub>**

**R717**  
Ammonia



NORTH AMERICAN  
**Sustainable  
Refrigeration  
Council**

# Debunking CO2 Myth's

Rusty Walker



# Booster Flex Low and Medium Temp Compressors





# It's Only Refrigeration





NORTH AMERICAN  
**Sustainable  
Refrigeration  
Council**

# It's To Complicated

# Basic R-744 (CO<sub>2</sub>) Booster System

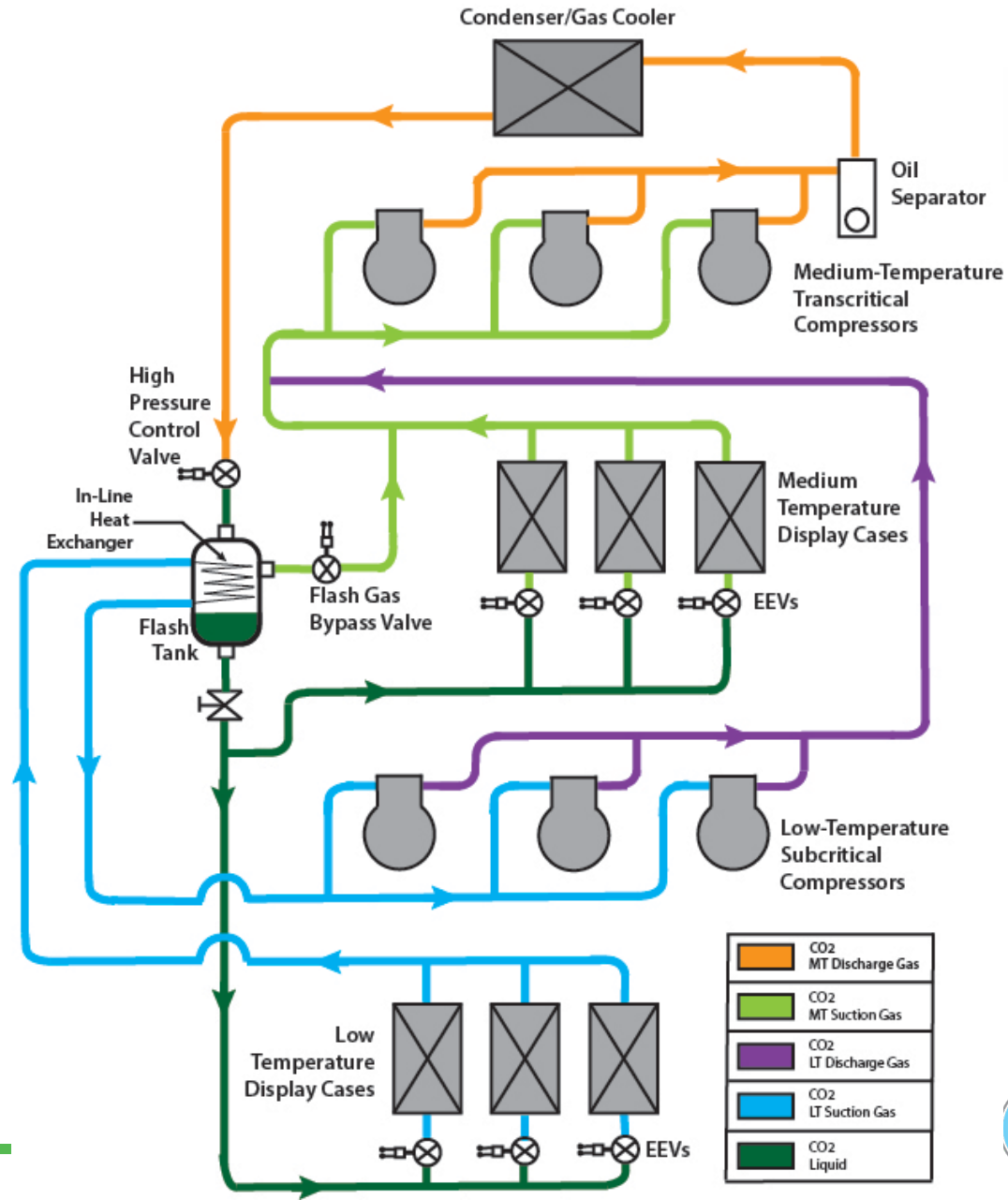

	CO <sub>2</sub> MT Discharge Gas
	CO <sub>2</sub> MT Suction Gas
	CO <sub>2</sub> LT Discharge Gas
	CO <sub>2</sub> LT Suction Gas
	CO <sub>2</sub> Liquid

**ADVANSOR**<sup>™</sup> *flex*



# Useful Definition

❑ **Supercritical Fluid** – This will occur when sufficient temperature and pressure is applied to take it beyond its critical point. The substances therefore no longer can be defined as being in either a liquid or gas phases..

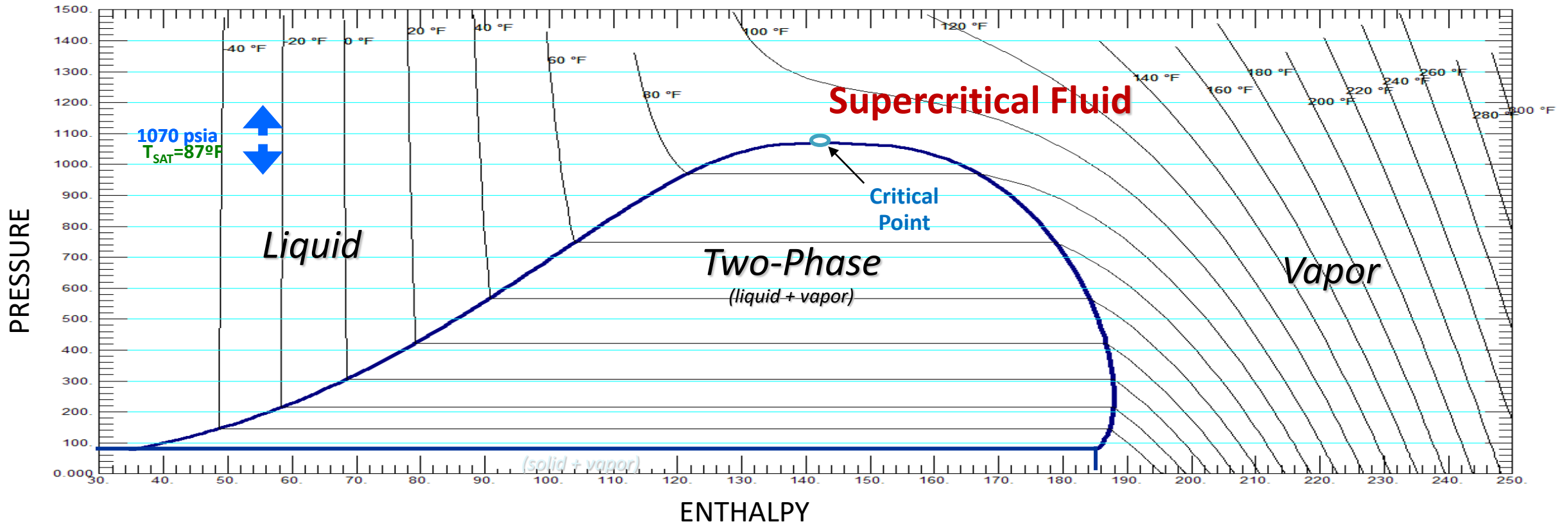

# Useful Definition

- ❑ **Transcritical Cycle** – Where the high side of the system operates **above** the critical point and the low side of the system operates **below** the critical point. **The system then transition between subcritical and supercritical and back again**

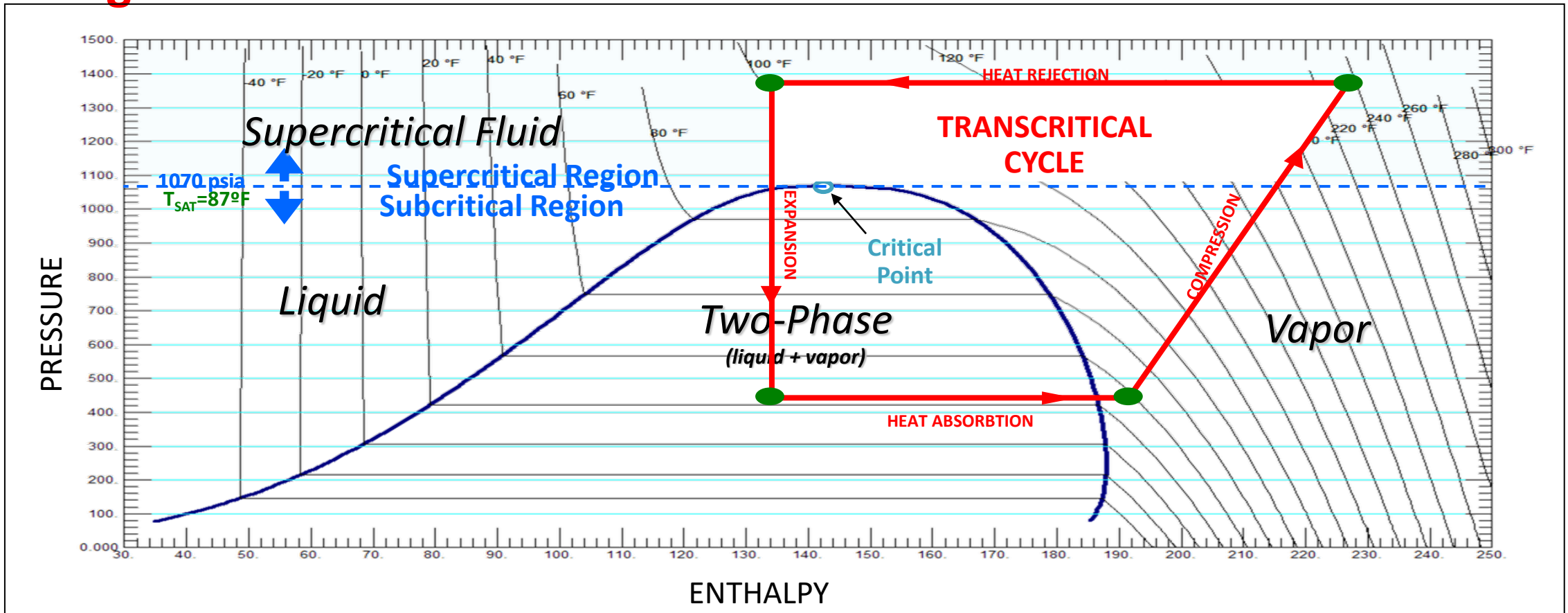

# Critical Point

- ❑ Critical Point- The very top of the refrigerant enthalpy diagram is the critical point. **At a temperature above 87.7°F or 1055psig CO<sub>2</sub> cannot exist as a liquid. The highest pressure and temperature where the refrigerant can still condense.**
- ❑ The liquid expands and becomes less dense until, **at the critical point, the densities of liquid and vapor become equal**, eliminating the distention between the two phases and merge together into a single phase.
- ❑ All Refrigerants have a critical point, CO<sub>2</sub> just has a low critical point vs. other refrigerants



# Critical Point of Other Refrigerants

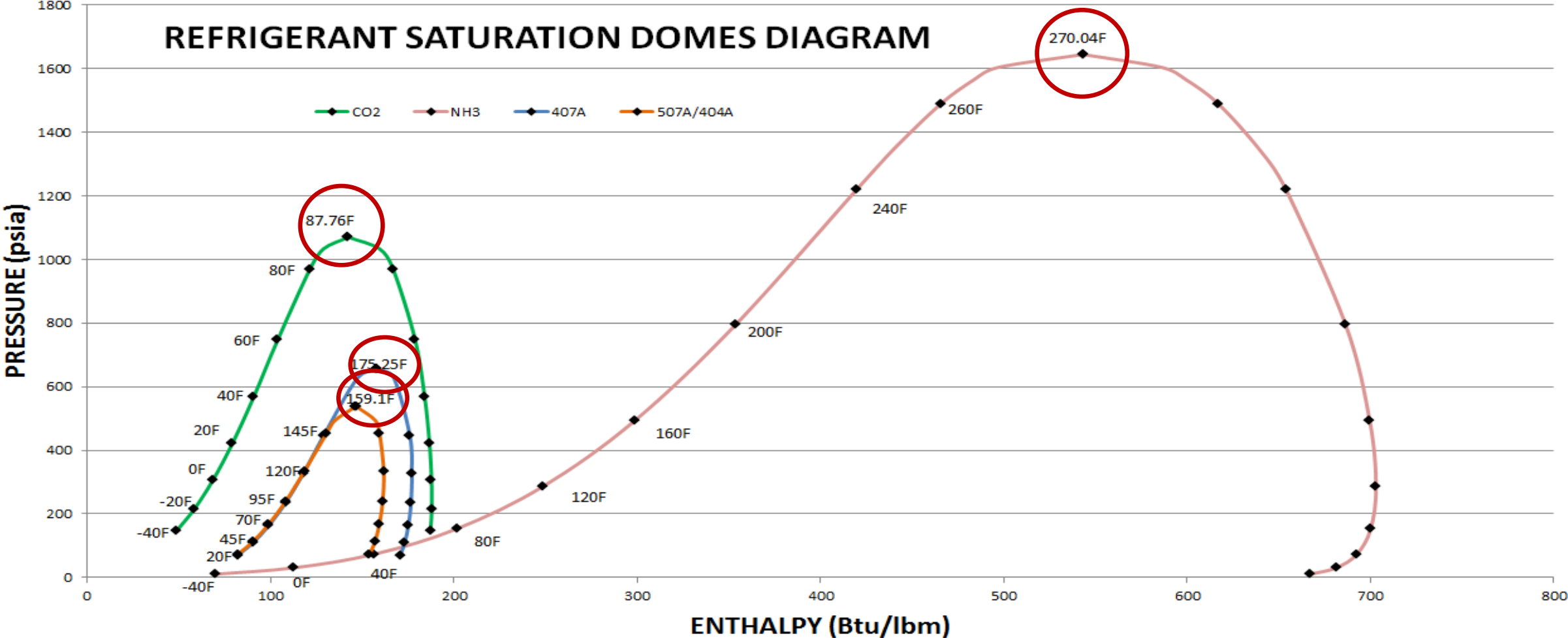

# Subcritical Operation

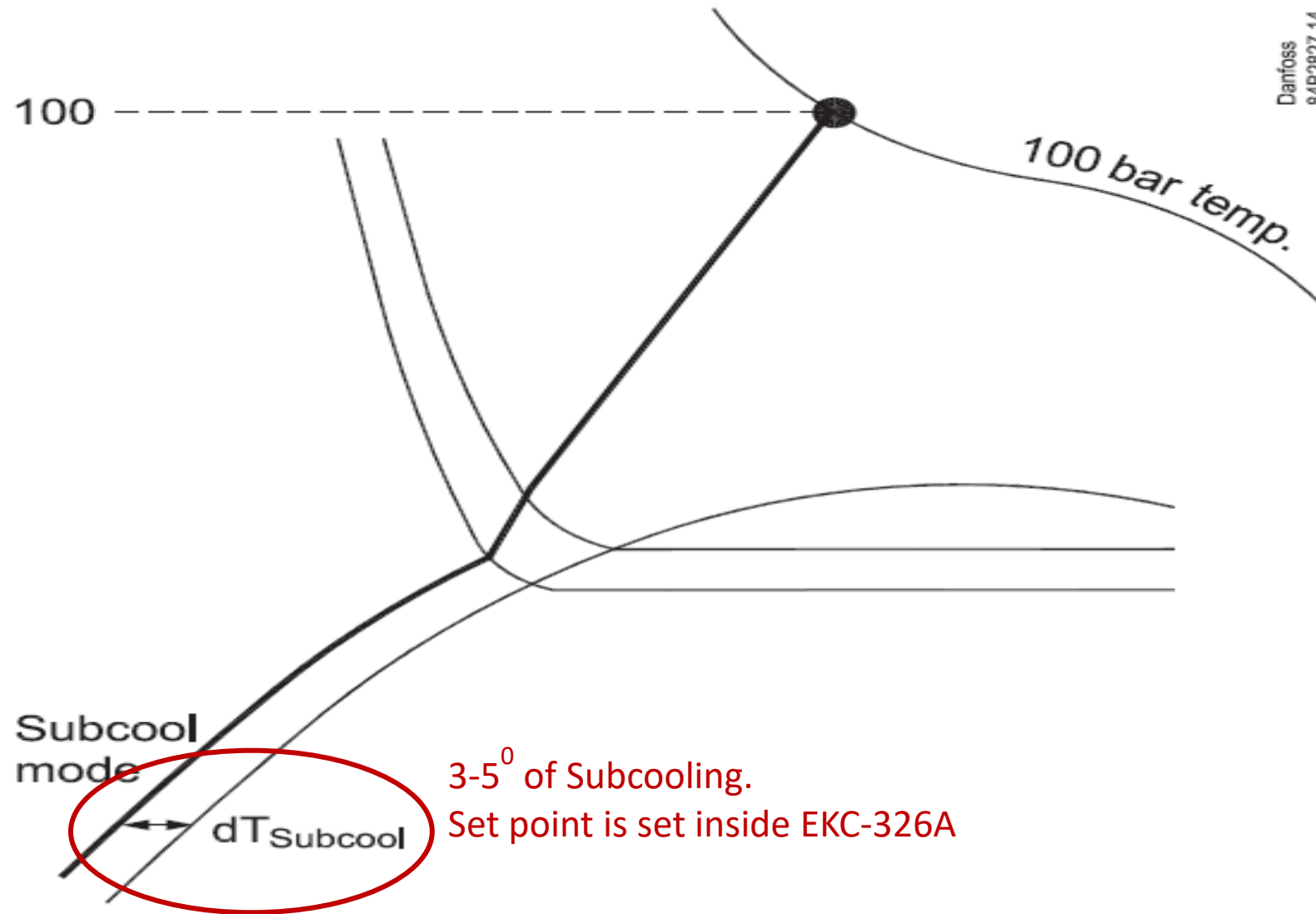

# Transcritical Operation

Maximum COP control  
The controller maintains optimum pressure in the transcritical range based on a pressure and temperature reading. The reference line is defined with a point at 100 bar. The desired temperature can be set here

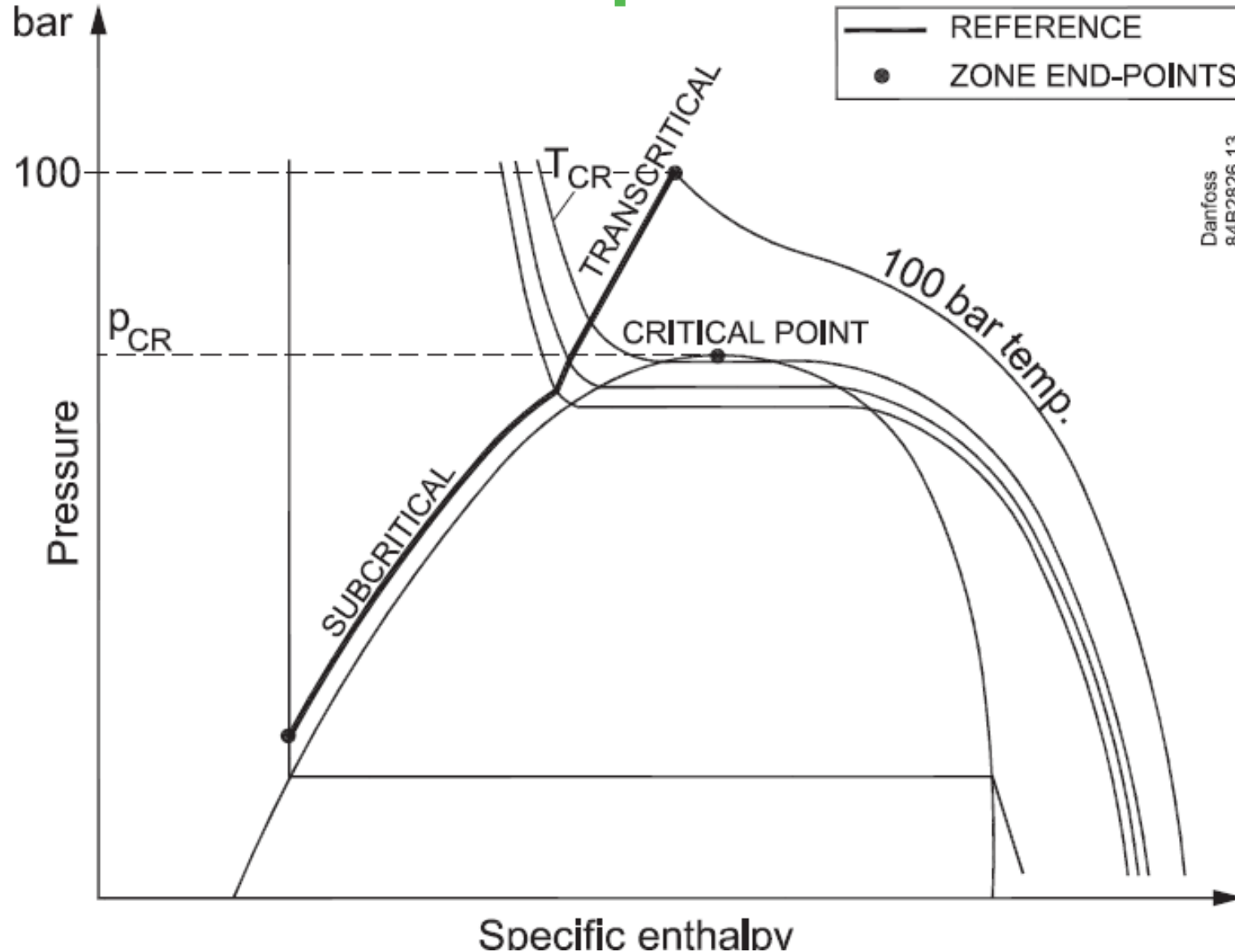

# Useful Definition

- **Triple Point** – The triple point is the pressure where all three phases of a substance (solid, liquid and vapor) can exist in equilibrium. The triple point of R-744 is **60 PSIG**



# CO<sub>2</sub> DX Case Line-Up with Isolation Valve

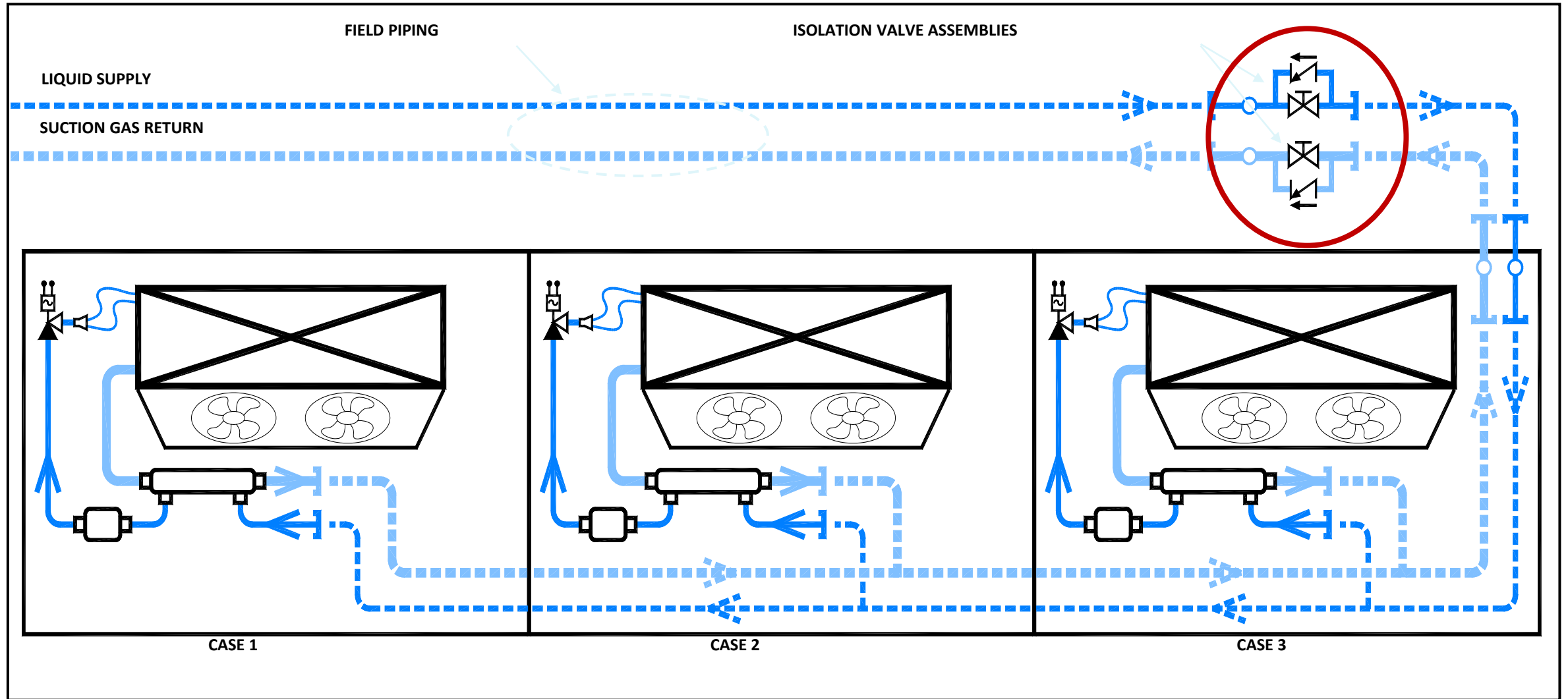



# Useful Definition

- **Sublimation** – The transition of a substance directly from the solid to the gas phase, without passing through the intermediate liquid phase.

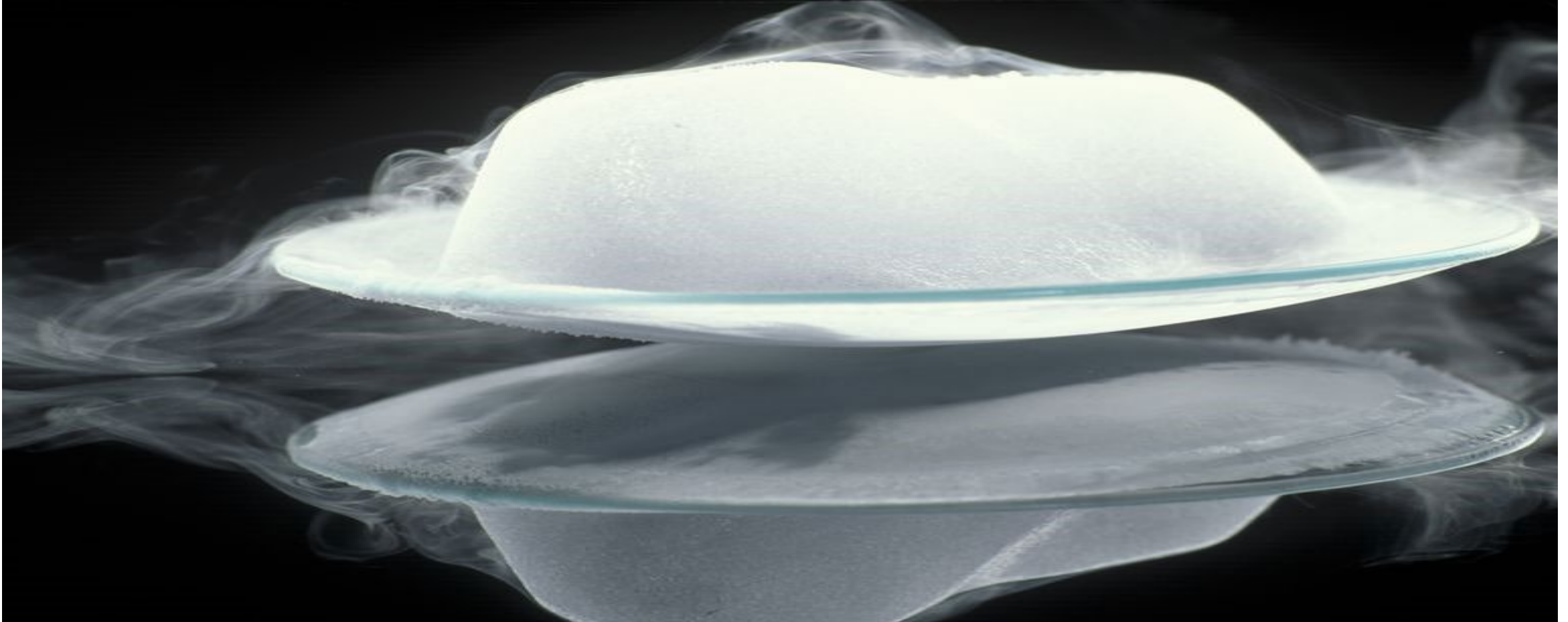



NORTH AMERICAN  
**Sustainable  
Refrigeration  
Council**

# Case Controllers

# LT Dixell Case Controller XM679K

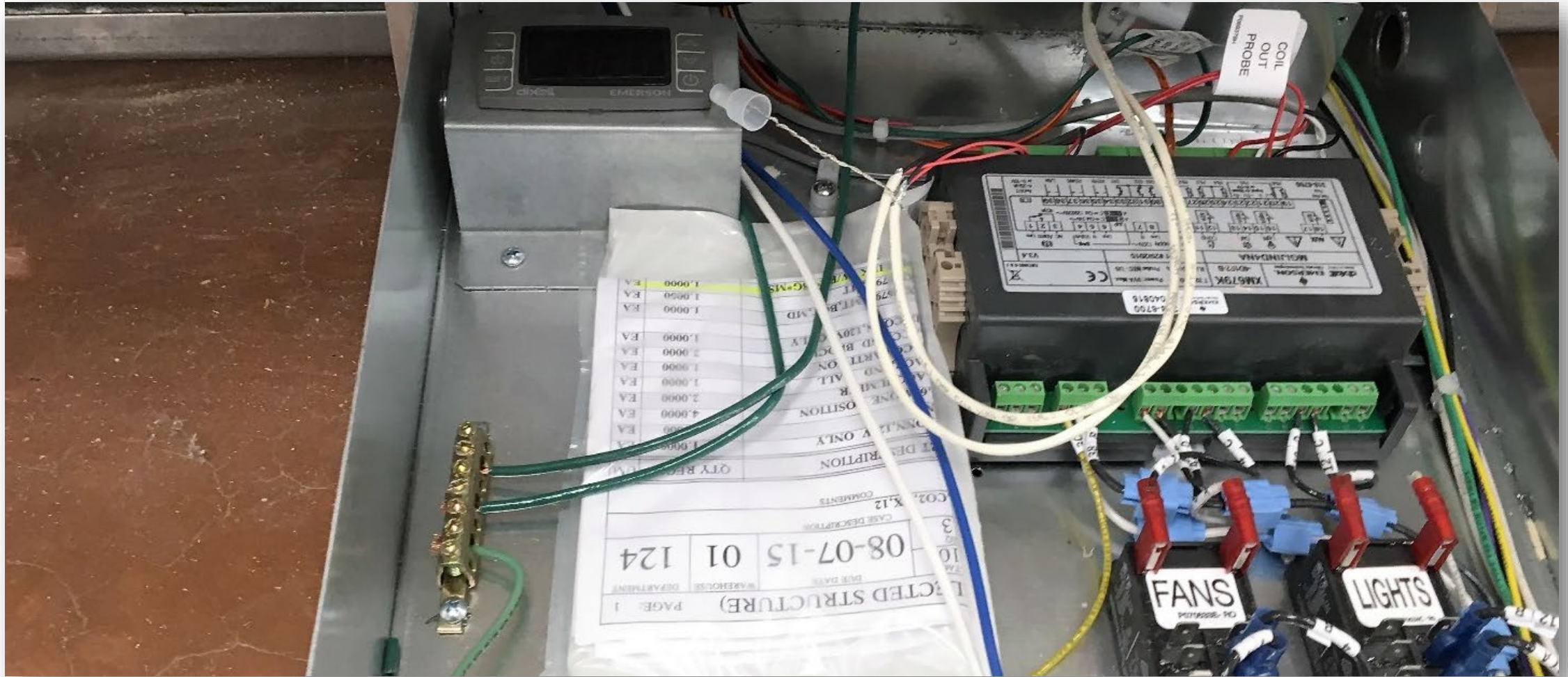

# AK-CC-550A Case Controller

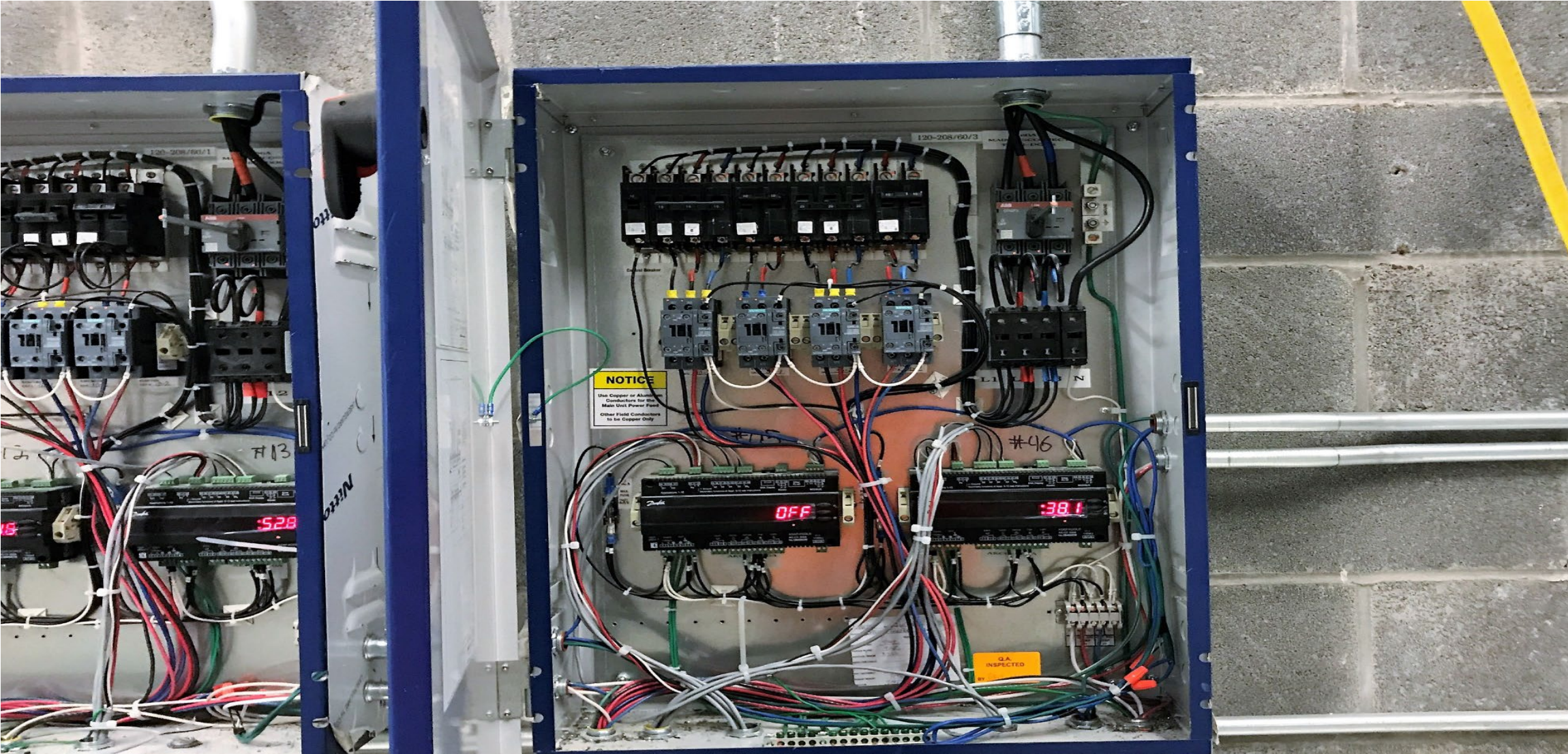

# Micro Thermo Evaporator Control



# Sporlan/MT Case Controller



# Controller Overview – S3C Case Control

## Electrical:

- Supply 22 to 26 VDC,
- 0.5 A minimum

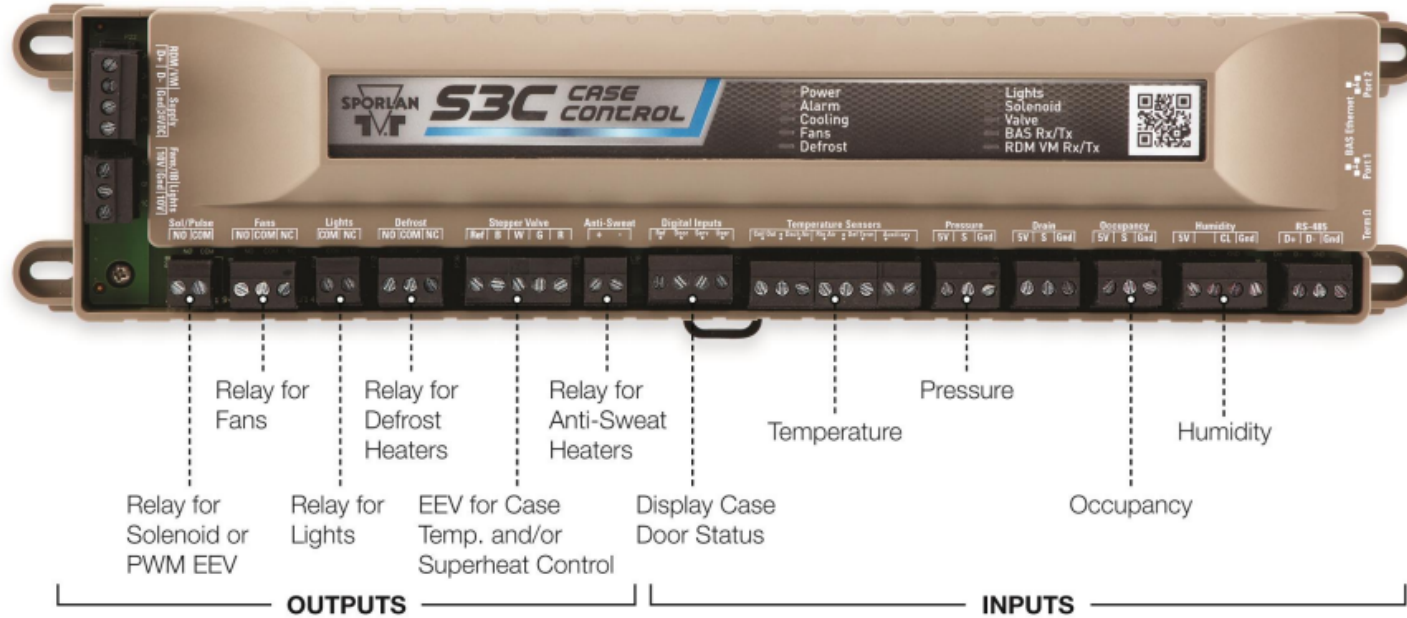

## Comm:

- 2 RS485
- 2 Ethernet

## Outputs:

- Two 0-10 VDC
- One 0-5 VDC (anti-sweat)
- 4 Relays (Defrost, Solenoid, Lights, Fans)
- 1 Stepper Valve
- 1 Pulse Valve / Solenoid

## Inputs:

- 3 Digital (Door, Service, User)
- 5 Temperature
- 1 Pressure
- Occupancy Sensor
- Humidity Sensor
- Defrost Amps

# Copeland Case Controller I/O wiring and Modbus

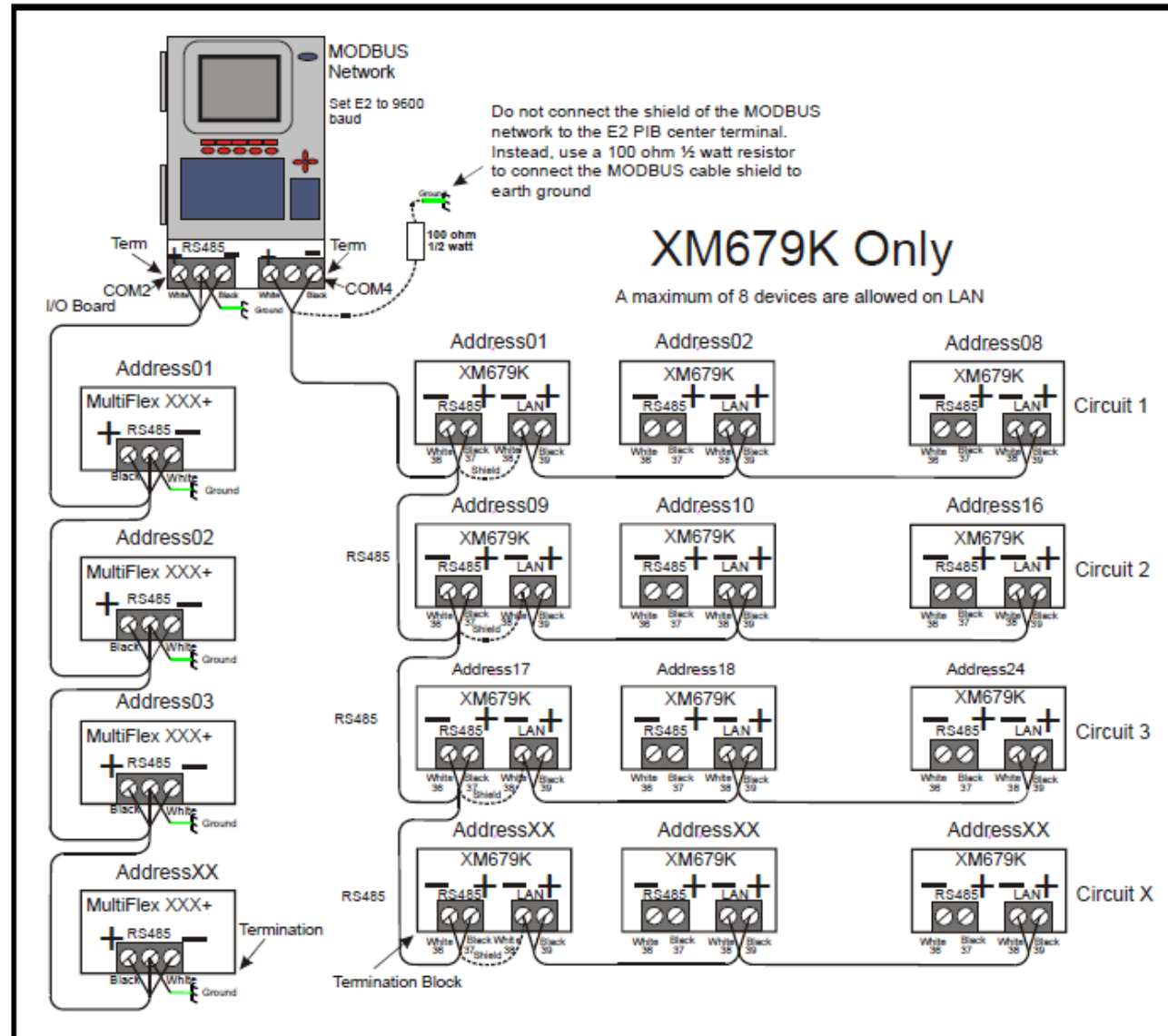

We recommend  
Belden 8641 twisted  
pair with a maximum of  
4000'



# Pico Scope





NORTH AMERICAN  
**Sustainable  
Refrigeration  
Council**

Is it a Leak Or An Event??



# Safety Relief Valve

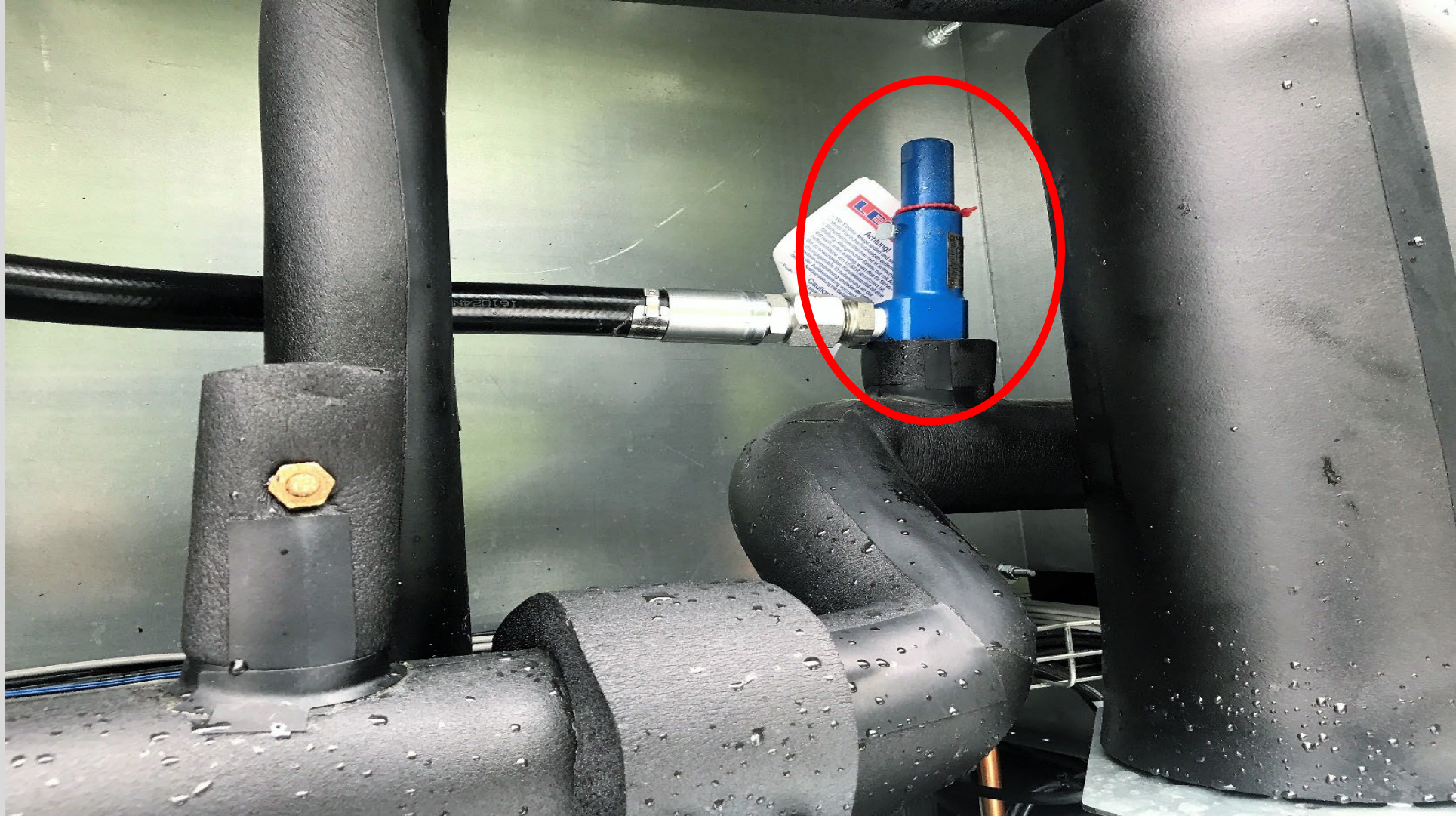

# Safety Relief Valve Manifold

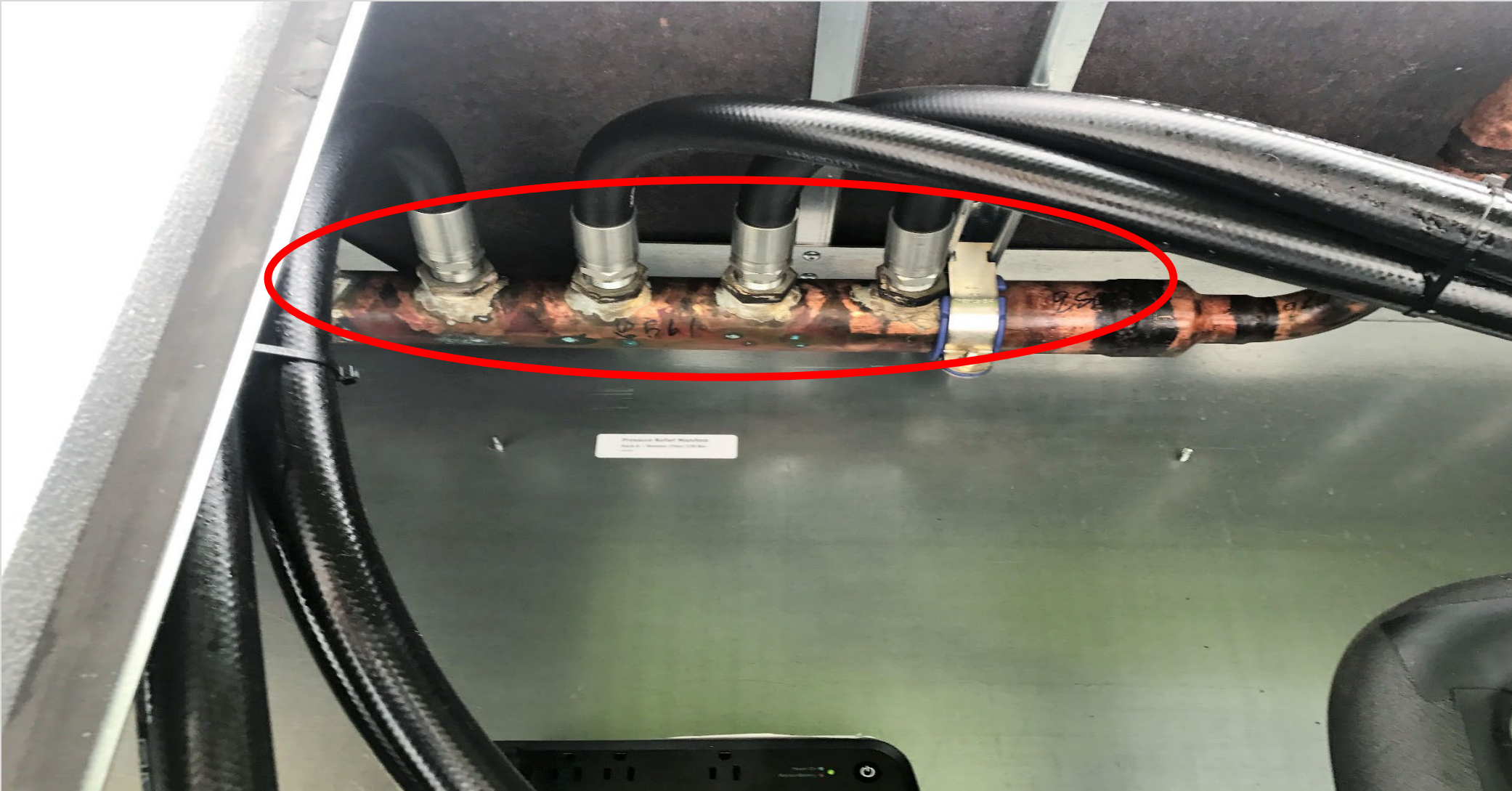



# Relief Valve Manifold Outlet



# Safety Relief Valve Manifold



# Liquid CO2 Tanks



# Liquid CO2 Tanks





# MT Grade of CO2





NORTH AMERICAN  
**Sustainable  
Refrigeration  
Council**

# Servicing in the Summer

# Westermeyer Coalescing Oil Filters



# Safety Relief Valve Manifold

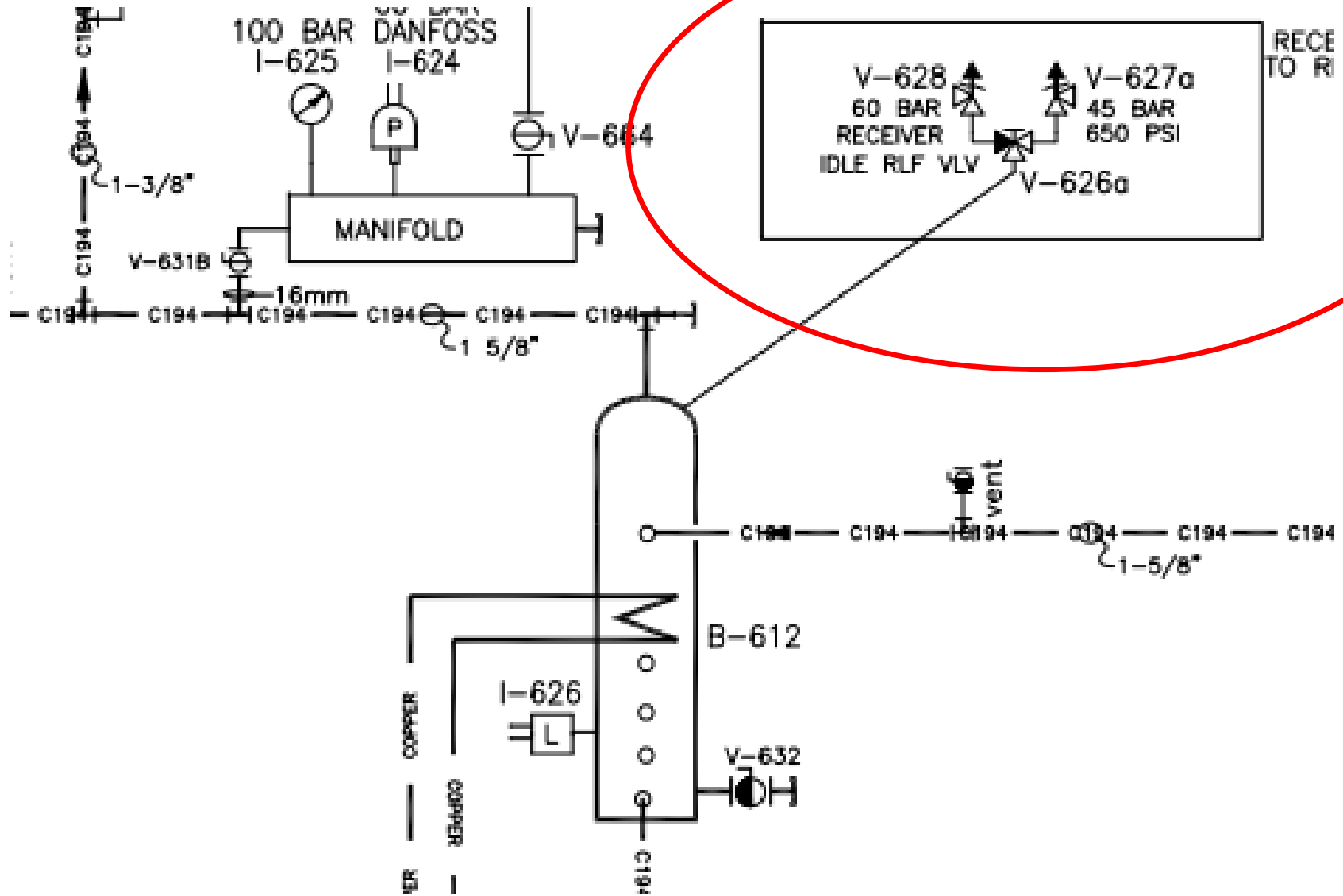

# Flash Tank Relief Valve

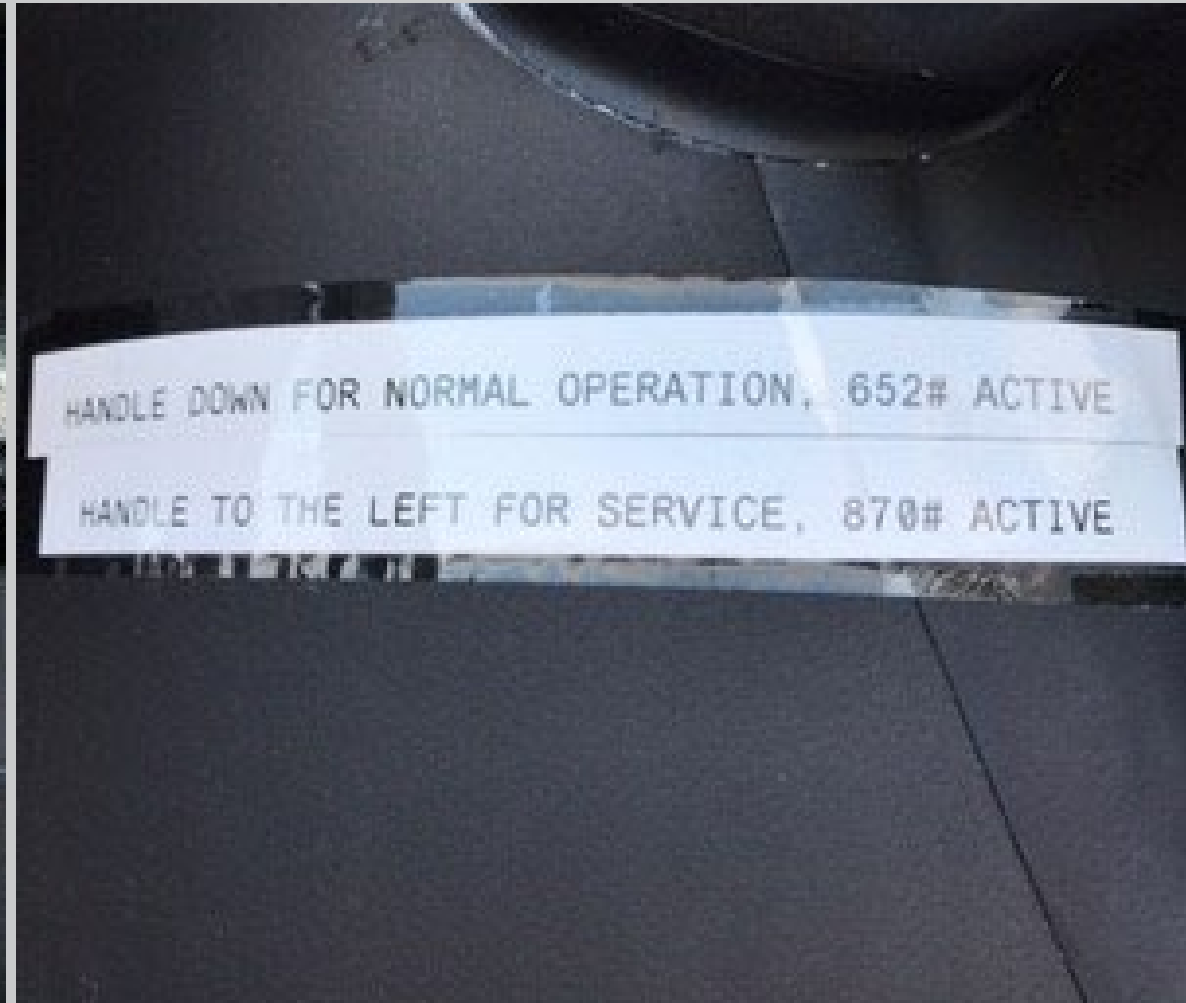

# Liquid Line Ball Valve



# Liquid Line Ball Valve



# Adiabatic Condenser/Gas Cooler





# Air-Cooled Condenser/Gas Cooler





NORTH AMERICAN  
**Sustainable  
Refrigeration  
Council**

# Charging Through The Evaporator

# It Was On The Internet



# Mueller Streamline Piping

## 2.A.1.a.i Mueller Streamline Copper Products

Refrigeration brazing is commonly performed at 900°F to 1300°F. **Take Note:** Temperatures in this range involve sufficient heat to anneal copper. Therefore, the working pressure ratings for all Streamline copper tube and wrot fittings should be based on performance in the annealed state—this is true whether referring to actual field brazing or to an annealing furnace. Following years of testing, the Mueller company is able to offer copper products rated for continuous up to **700 psi at 250°F**, as identified in the table provided below. All of these values have already been de-rated for brazing.

Product Line	Product Type	Diameters
Copper Tube	• Streamline Refrigeration Service Coils	1/8" to 1 1/8"
	• Streamline Line Sets & Mini-Splits	1/8" to 1 1/8"
	• Streamline ACR - Type L (Hard Lengths)	1/8" to 1 3/8"
	• Streamline ACR - Type K (Hard Lengths)	1/8" to 2 5/8"
Copper Fittings	• Streamline ACR - Wrot Solder - Joint Pressure	1/8" to 2 5/8"



NORTH AMERICAN

**Sustainable Refrigeration Council**

# Charging CO<sub>2</sub> Into a Booster



# Charging CO2 Into a Booster Charging Port

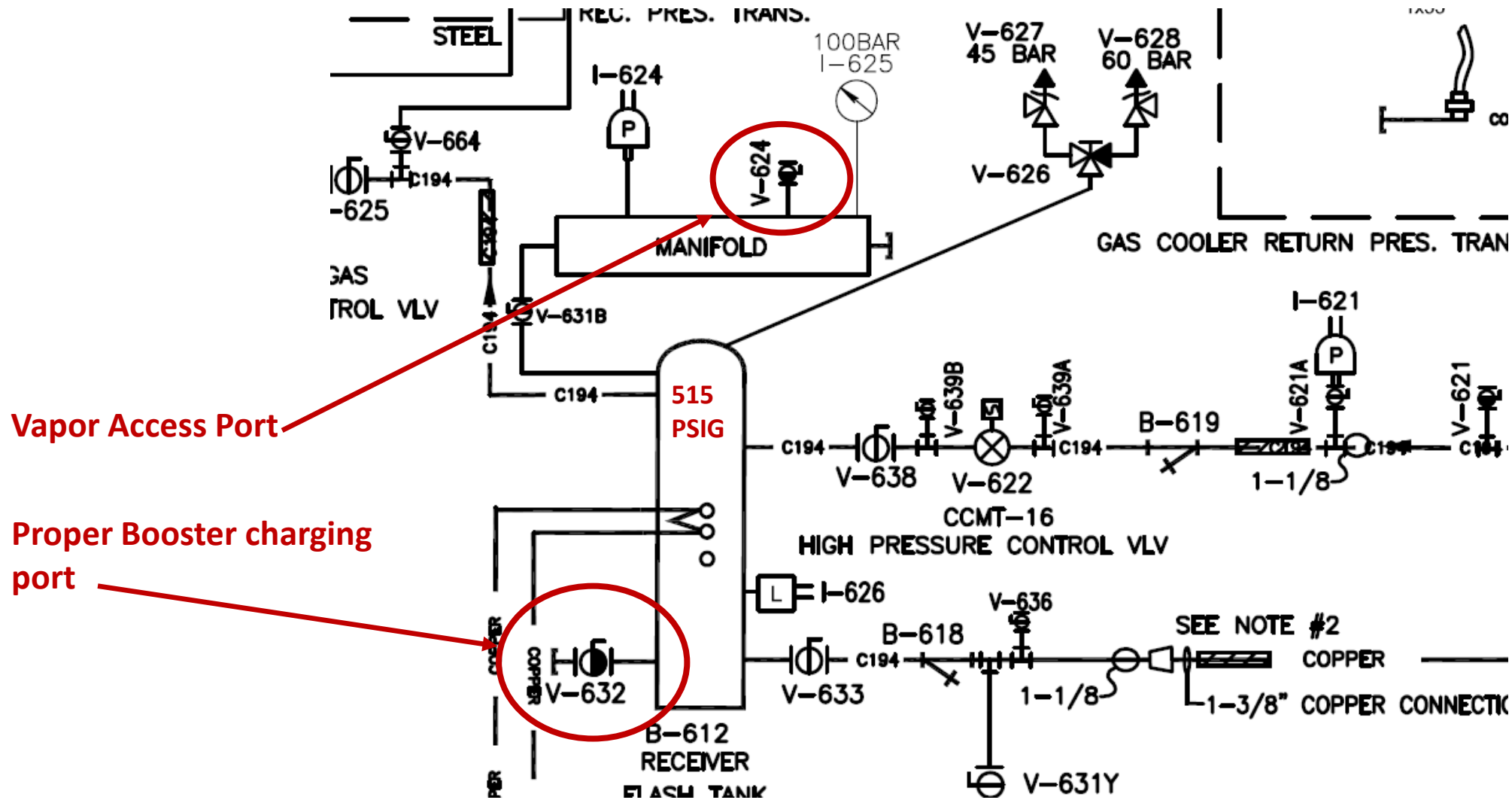



NORTH AMERICAN  
**Sustainable  
Refrigeration  
Council**

# Not Enough Trained Technician



# Certification

*Partnership  
In  
Training Excellence*



# Classroom Training



Good training starts with classroom instruction giving service technician a strong understanding of how the system is works.

The Learning Center has trained 8000+ service technicians and installers

We have trained technicians who work with both commercial and industrial CO2 systems

Since 2006 the Learning Center has conducted CO2 training on all types of CO2 Refrigeration Systems.

CO2 Secondary Overfeed

CO2 Cascade

CO2 Booster

CO2 Secondary Overfeed MT/Cascade LT



# Hands-On Training

Most technicians are visual learners, so after the classroom it important to get as much hands-on training as possible. Onsite is the best place for this type of training



Since the beginning we have trained onsite and in many different locations, such as; NYC, Seattle, LA, Miami and Chicago.

We have also trained in smaller community's like, Duluth MN, Sioux Falls SD, Scranton PA, Waco TX, and Jupiter FL.





NORTH AMERICAN  
**Sustainable  
Refrigeration  
Council**

I Have Dry Ice In My System!!!!!!

## Useful Definition

- **Triple Point** – The triple point is the pressure where all three phases of a substance (solid, liquid and vapor) can exist in equilibrium. The triple point of R-744 is **60 PSIG**



# CO<sub>2</sub> DX Case Line-Up with Isolation Valve

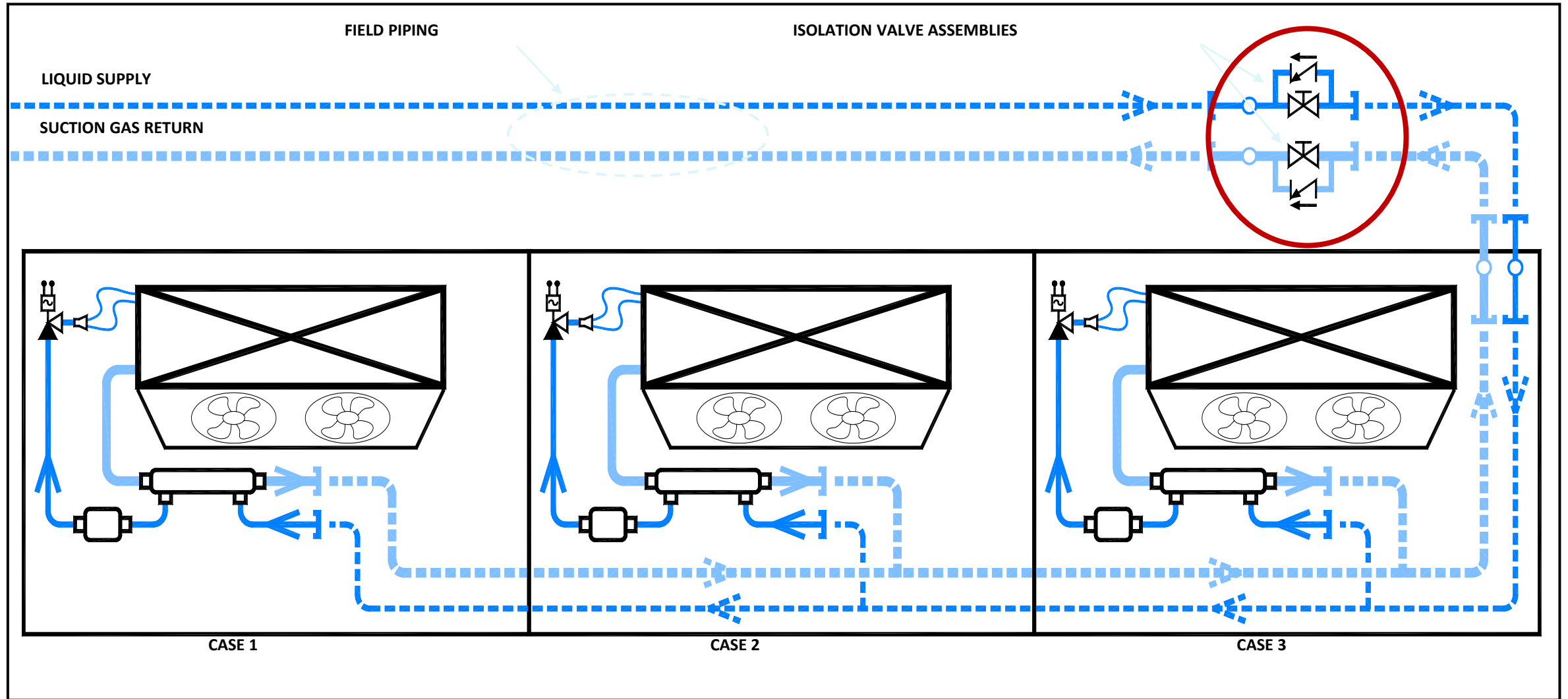

# Useful Definition

- **Sublimation** – The transition of a substance directly from the solid to the gas phase, without passing through the intermediate liquid phase.

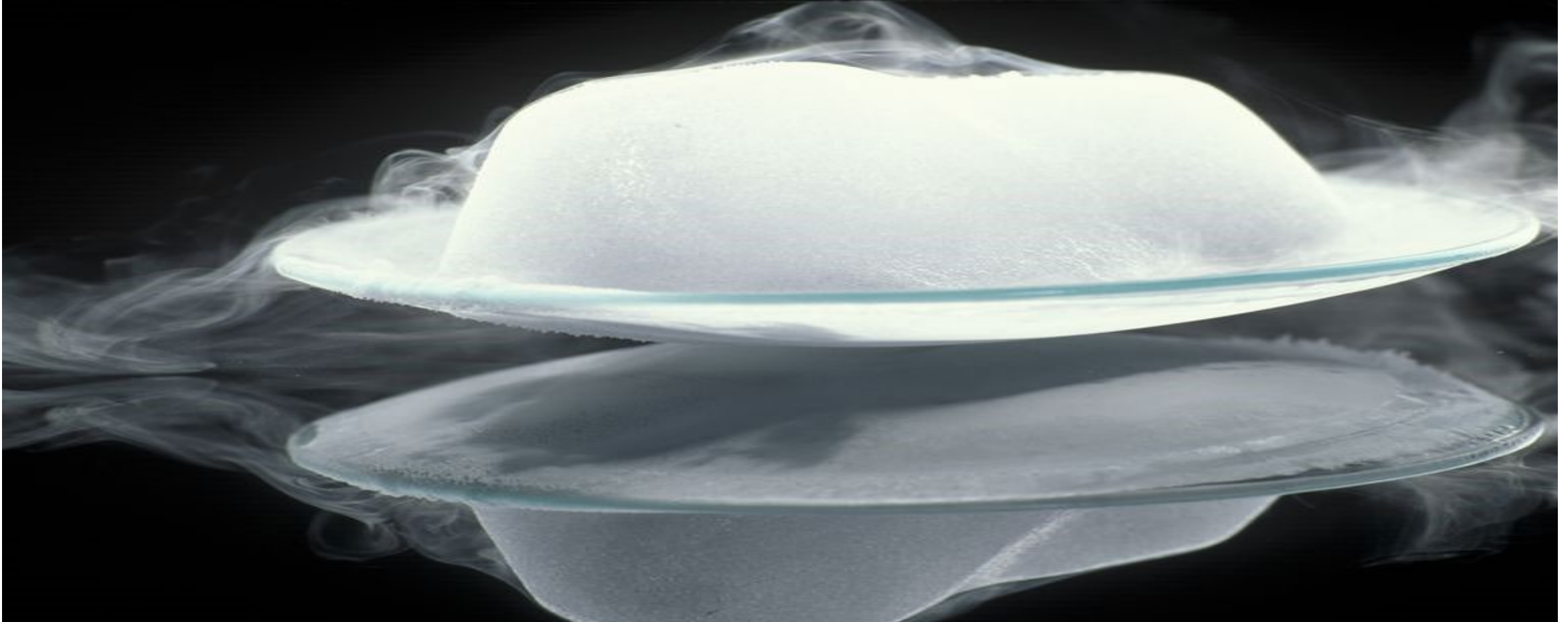



# Questions?